

~~SECRET~~
APRIL 1957

~~SECRET~~

**PROGRAM PLANNING REPORT
PROJECT 1794
EXTENSION PROGRAM**

Prepared in accordance with initial Statement
of Work dated 18 December 1956 - Revised
11 February 1957.

Exhibit 1 identified 57MCP5901

Supplementary Agreement #3 to Contract No.
AF33(600)30161

DECLASSIFIED

Authority NND 63253



AVRO AIRCRAFT LIMITED

SECURITY WARNING

This document is intended solely for the recipient and such persons as have been delegated to use it in the course of their duty and may be used in connection with work performed for or on behalf of the United States Air Force.

The transmission, unauthorized retention, destruction, or the revelation of its contents, in any manner, to any unauthorized person(s) is forbidden.

Failure to comply with any of the above instructions is an infraction of the Canadian Official Secrets Act and is a violation within the meaning of the United States Espionage Laws, title 18, U.S.C., sections 793 and 794.

This copy has been issued by Avro Aircraft Limited, Malton.

To -

Date -

Copy No. - **1**

PROGRAM PLANNING REPORT

PROJECT 1794

EXTENSION PROGRAM

Prepared in accordance with initial Statement of Work
dated 18 December 1956 - Revised 11 February 1957, Exhibit 1

identified 57MCP5901

Supplementary Agreement #3

to

Contract No. AF33(600)30161

Issued by:

Avro Aircraft Limited
Malton, Ontario, Canada

Approved by

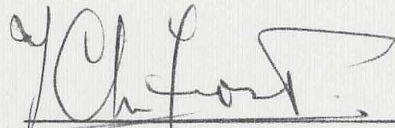

J. C. M. Frost
Chief Design Engineer
Special Projects Group
Avro Aircraft Limited

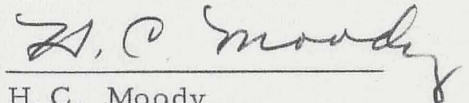

H. C. Moody
Engineering Manager
Special Projects Group
Avro Aircraft Limited

The number of pages in this report including Security Warning, Title,
Frontispiece, Table of Contents, Illustration sheets and Exhibits is 121.

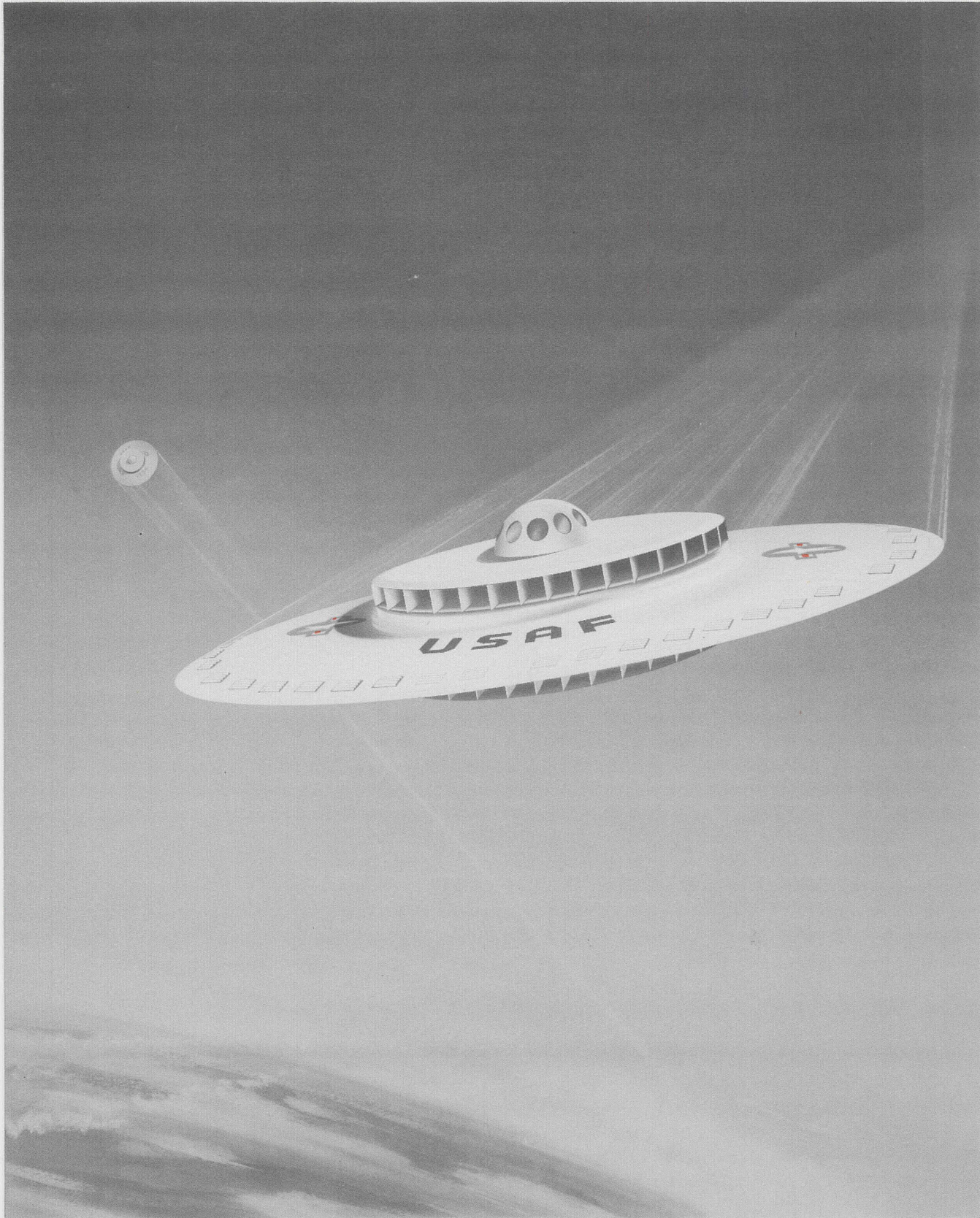
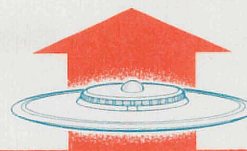

1808-704-1

USAF PROJECT 1794

726-1794-1

TABLE OF CONTENTS

| SECTION | TITLE | PAGE |
|---------|--|------|
| 1 | SUMMARY | 1 |
| 2 | INTRODUCTION | 2 |
| 3 | DESIGN AND PERFORMANCE | 12 |
| 4 | AERODYNAMICS | 19 |
| 5 | PROPULSION | 48 |
| 6 | STABILITY AND CONTROL | 72 |
| 7 | STRUCTURES | 84 |
| 8 | REPORTS AND CONSOLIDATED WORK AND COST CHARTS | 92 |
| 9 | COMPANY STATEMENTS Exhibit 1 Exhibit 2 | 108 |

LIST OF ILLUSTRATIONS

| FIGURE | TITLE | PAGE |
|--------|--|------|
| 1 | Plan View and Section Through Aircraft ✓ | 3 |
| 2 | Cutaway of Aircraft Structure ✓ | 4 |
| 3 | Turbine - Compressor Assembly ✓ | 5 |
| 4 | A. S. Viper Engine Installation ✓ | 6 |
| 5 | Flame Tube and Final Nozzle Assembly | 8 |
| 6 | Flow Distribution - Hovering and Ground Cushion | 9 |
| 7 | Work Chart - Design and Performance | 17 |
| 8 | Work Schedule Chart - Design and Performance | 18 |
| 11 | Proposed 1/12 Scale Transition Model | 20 |
| 12 | 1/6 Scale Model in Tunnel | 22 |
| 13 | 1/6 Scale Model | 23 |
| 14 | Proposed 1/12 Scale Transonic Reflection Plane Model | 25 |
| 15 | 2/25 Scale Air Intake Model | 27 |
| 16 | 2/25 Scale Air Intake Model | 28 |
| 17 | Proposed Changes to 2/25 Scale Model | 29 |
| 18 | 1/40 Scale Sting Mounted Model | 30 |
| 19 | 1/40 Scale Sting Mounted Model | 31 |
| 20 | 1/40 Scale Sting Mounted Model | 32 |
| 21 | 1/23 Scale Supersonic Model | 34 |
| 22 | 1/23 Scale Supersonic Model | 35 |
| 23 | Proposed Changes to 1/23 Scale Model | 36 |
| 24 | 1/3 Scale Nozzle Rig | 38 |
| 25 | 1/3 Scale Outer Wing Segment Test Rig | 39 |

LIST OF ILLUSTRATIONS (Cont'd)

| FIGURE | TITLE | PAGE |
|--------|--|------|
| 26 | 1/5 Scale Air Intake Model | 42 |
| 27 | Intake Arrangement | 43 |
| 28 | Ground Effects Rig | 44 |
| 29 | Ground Effects Rig | 45 |
| 30 | Work Chart - Aerodynamics | 46 |
| 31 | Work Schedule Chart - Aerodynamics | 47 |
| 34 | Schematic of Propulsion Control System | 50 |
| 35 | Viper Air Intake | 52 |
| 36 | Exhaust Fantail Test | 53 |
| 37 | Viper Air Intake and Exhaust Fantail | 54 |
| 38 | Overspeed Rig ✓ | 55 |
| 39 | Balance and Overspeed Rig ✓ | 56 |
| 40 | Test House and Six Viper Test Rig ✓ <i>new built</i> | 57 |
| 41 | Combustion Entry Mach No. | 60 |
| 42 | Combustion Entry Pressure and Temperature | 61 |
| 43 | Estimated Combustion Efficiency and Extinction Limits | 62 |
| 44 | Six Viper Test Rig with Outer Wing and Cockpit <i>new step</i> ✓ | 67 |
| 45 | Work Chart - Propulsion | 70 |
| 46 | Work Schedule Chart - Propulsion | 71 |
| 49 | Schematic of Shutter Control System | 73 |
| 50 | Frequency Response Rig No. 1 | 77 |
| 51 | Frequency Response Rig No. 1 | 78 |
| 52 | Schematic of Control System Mechanical Analogue | 80 |

LIST OF ILLUSTRATIONS (Cont'd)

| FIGURE | TITLE | PAGE |
|--------|---|--------|
| 53 | Work Chart - Stability and Control | 82 |
| 54 | Work Schedule Chart - Stability and Control | 83 |
| 57 | Proposed Stressing Reports for P. V. 704 | 85 |
| 58 | Proposed Stressing Reports for Design Studies | 87 |
| 59 | Work Chart - Structures | 90 |
| 60 | Work Schedule Chart - Structures | 91 |
| 65 | Consolidated Work Chart | 94 |
| | Manhour and Cost Estimates | 95-108 |

1. SUMMARY

This document details a planned program for the further development of the Avro Aircraft Limited VTOL aircraft concept, designated Project 1794, with accompanying cost estimates and scheduling.

The program is prepared in accordance with initial Statement of Work dated 18 December 1956, as revised 11 February 1957, Exhibit 1, identified 57MCP5901. The work proposed parallels the private venture construction of a flying prototype presently being undertaken by Avro Aircraft Limited, and data obtained from the latter program, as and to the extent called for in the above exhibit, will be reported as part of the USAF program. A consolidated work chart, in Section 8 of this report, illustrates the tie-in between the company program, designated P. V. 704 and that of the USAF.

In order that the significance and context of this program may be appreciated, a brief description of P. V. 704 is given in the Introduction. Following this, the USAF program is presented under six headings and wherein the P. V. 704 planning is concurrently described. Work charts, costs, manhour requirements and scheduling down to and including three digit sub parts of the Statement of Work are also included.

Funding required against the USAF program amounts to the sum of \$1,483,847 in Canadian Funds. This sum includes \$180,000 for the supply of six ASV Viper 8 engines, and \$430,960 for the Design and Development of the Combustion and Fuel Systems as per Statement of Work sub part 1.1.7. Wind Tunnel costs are not included.

The contract period will be twenty months, starting 1 February 1957, ending 31 October 1958.

2. INTRODUCTION

The Avro VTOL aircraft is essentially a proposal for a high performance supersonic aeroplane in which the entire interior of the wing is utilized for the propulsion system, air and gas flow, having also - due to the characteristics of the propulsion system and the wing planform - a VTOL-STOL capability.

The concept was developed by Avro to its present form and was reviewed as to feasibility under a study contract with USAF AF. 33(600)30161 (supplemental agreement No 1), which was completed in July 1956.

This development program, involves further tests to investigate the potentialities of this type of aeroplane, with study of application to a weapon system, and supplements the Avro Aircraft Limited company program (P. V. 704) which covers the building of one flying prototype.

In order that the significance and context may be appreciated the general layout of P. V. 704 is given in Figs. 1 through 6 and described as follows:

Fig. 1 is a plan and section drawing of the aircraft. It is 35.3 ft. in diameter; stands about 2 ft. off the ground, measures 7.7 ft. from the lower surface to the top of the canopy; is approximately symmetrical in section and is expected to weigh about 20,000 lb. with 5,700 lb. fuel.

Six Armstrong Siddeley Viper turbo-jets - 1,900 lb. thrust, 22 inch overall diameter, 570 lb. weight each - are mounted radially in the wing, exhausting inward; and used as gas generators to drive a pair of contra-rotating compressors by means of a radial in-flow turbine. (See the section cut-away Fig. 2).

The 8 ft. diameter compressors (Fig. 3), which rotate slowly by comparison with conventional turbo-jets, draw air from the upper and lower intakes (Fig. 2) and force it radially out through the wing between the Viper engines. Some of the air thrown out by the compressors is directed back to feed the Viper engines (Fig. 4).

The air is diffused in the wing to a high pressure at the flame holders (Fig. 1), where fuel may be added to augment the thrust, and is then exhausted through pneumatically

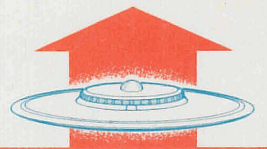

2156-704P-1A

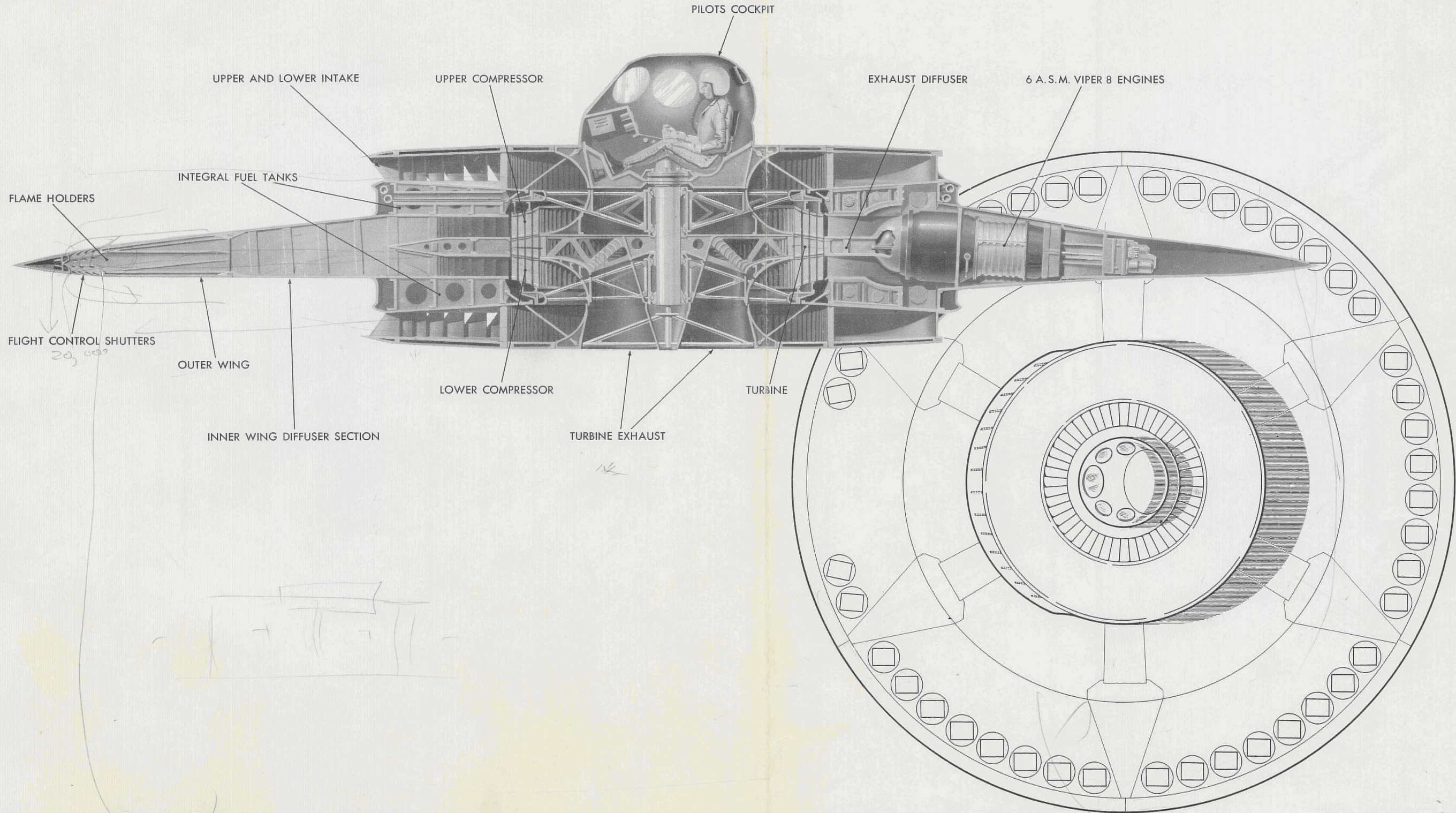
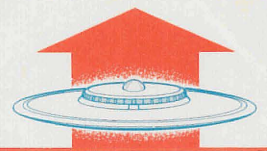

Fig. 1 Plan view and section through aircraft



2135-1794-2

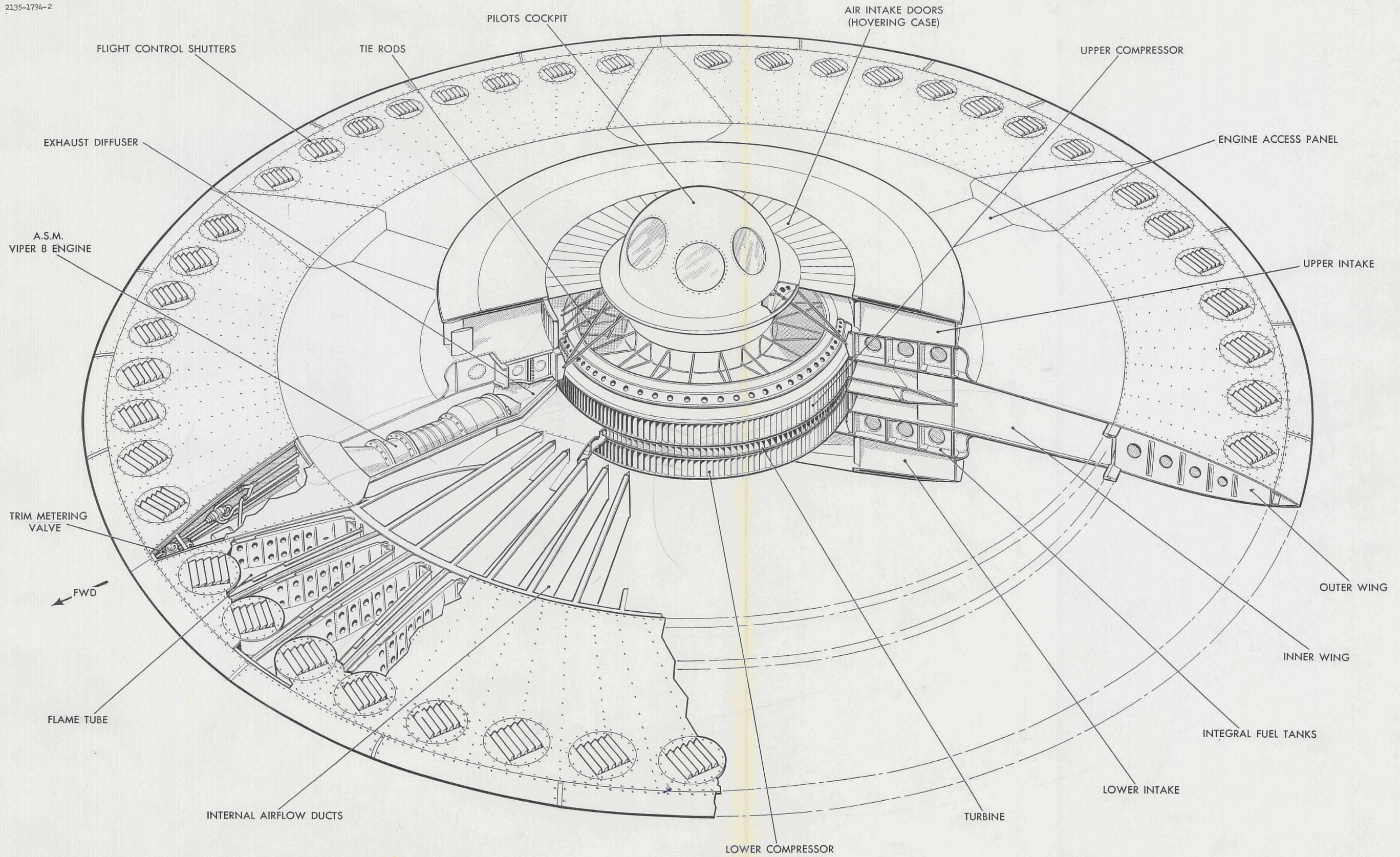

FIG. 2 CUTAWAY OF AIRCRAFT STRUCTURE

SECRET

727-1794-1

1927-704-2

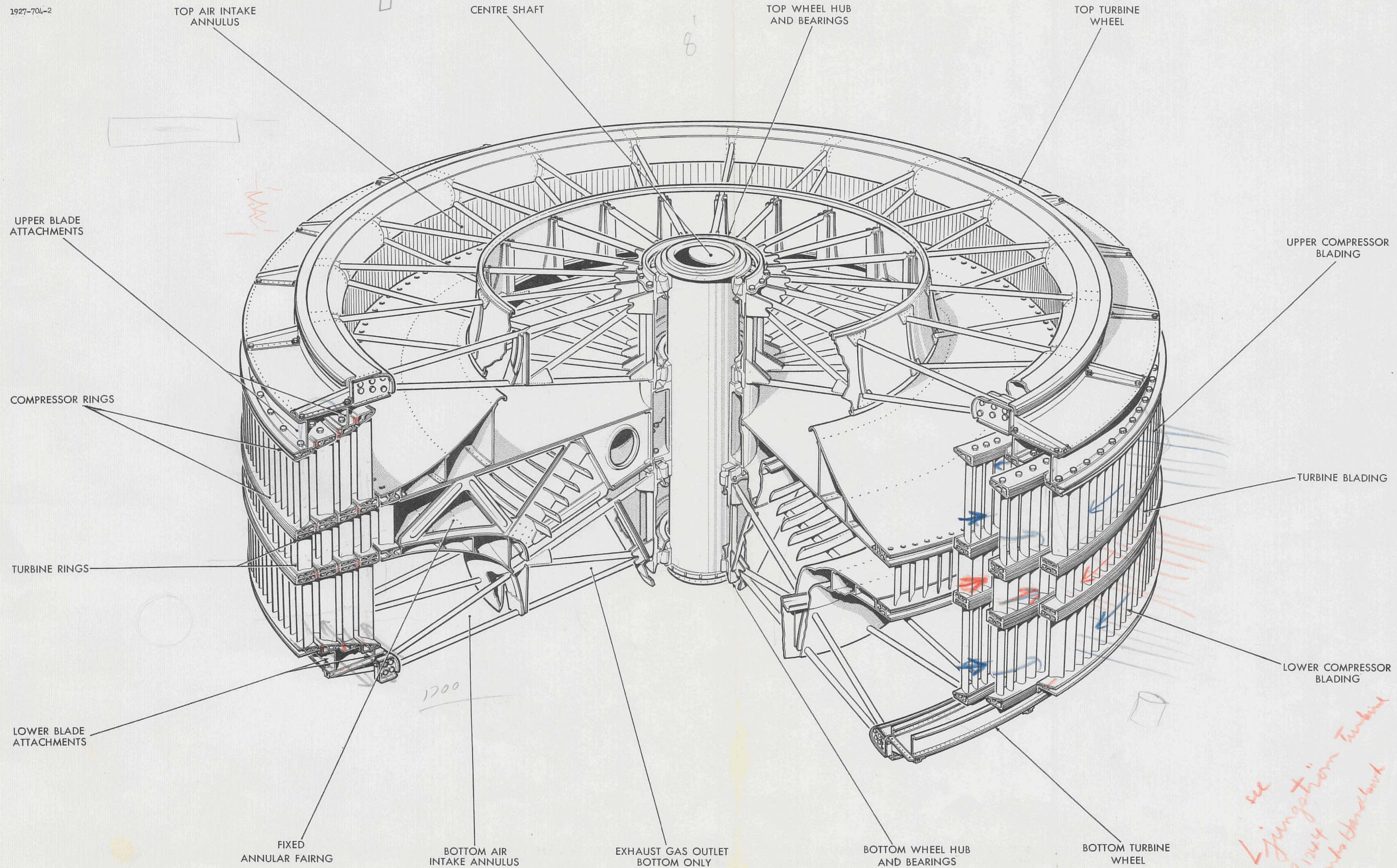

FIG. 3 TURBINE-COMPRESSOR ASSEMBLY

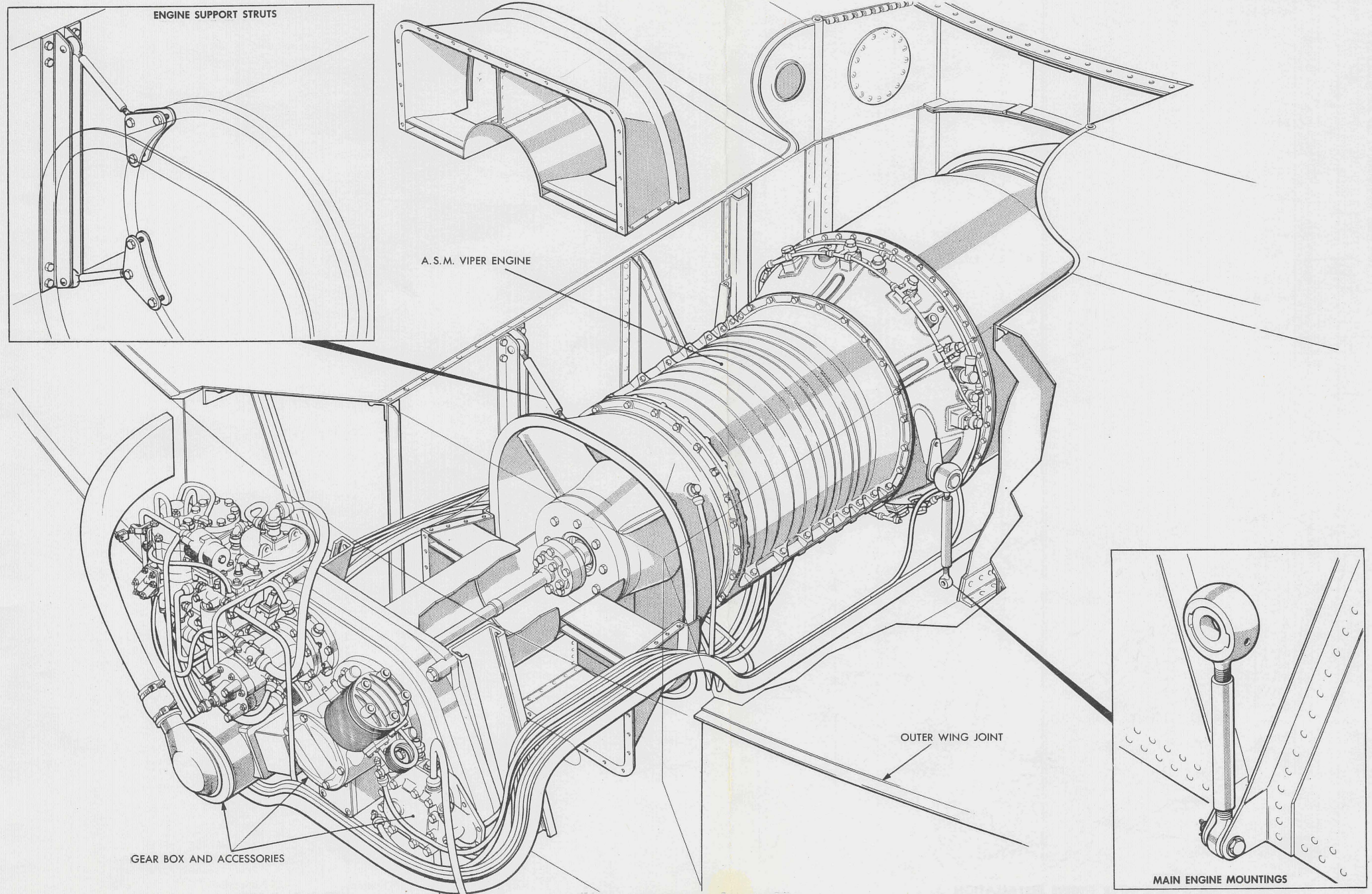
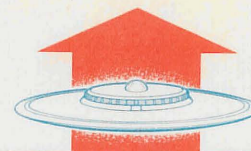

FIG. 4 A.S. VIPER ENGINE INSTALLATION



controlled shutters or gills (Fig. 5) which direct the jet as it exhausts all around the aircraft periphery; either to raise the aircraft vertically off the ground or to propel it in forward flight. This control of the exhaust direction enables the jets to be used for manoeuvring and stabilizing the aircraft in all flight conditions, so that separate additional controls are not required to cater for vertical take-off and hovering. Thus, for instance, to pull up the nose of the aircraft the pilot will control the shutters by means of a conventional stick control to direct the jet out of the top of the wing in the rear sector and thrust the tail down, or to roll he will similarly direct the jet from the top of one wing and from the bottom of the other. For stabilizing, the main rotors and a differential pressure diaphragm at the front of the wing are used to sense when the aircraft pitches in a gust and use is made of the jet controls to correct it. Stabilization through the controls is essential on this aircraft since the centre of gravity is in the middle of the wing at half the chord from the leading edge, whereas the aircraft would only be stable in pitch without using the controls if the centre of gravity were about at the quarter chord position. The change in jet direction as the aircraft pitches performs the same function as the fixed stabilizer of a conventional aircraft. For a detail explanation of the stabilizer system see Section 6.

In operation, to take-off, all the shutters on the top of the wing are closed and the shutters on the bottom are opened wide. Without adding fuel to augment it, a total of about 20,000 lb. thrust is produced by the jets pointing downward all around the wing together with the central nozzle; however, this jet-around-wing configuration produces a powerful take-off ground cushion so that the lift on the aircraft is, in fact, increased to possibly 30,000 lb., and the aircraft rises to about 17 ft. (Fig. 6) where the ground cushion effect falls off rapidly. For vertical take-off the thrust must be greater than the weight and thus without afterburning the fuel capacity will be restricted to approximately 3,500 lb: if afterburning to 1200°K proves feasible statically, approximately 30,000 lb. thrust can be produced, or 45,000 lb. lift within the ground cushion. It is envisaged that transition to forward flight will normally be from the ground cushion. By operating a transition control the pilot leans the jets backwards gradually, to accelerate the aircraft, and raises the nose; with the thrust less than the weight, the aircraft can accelerate and rise into free air a short distance from the starting point.

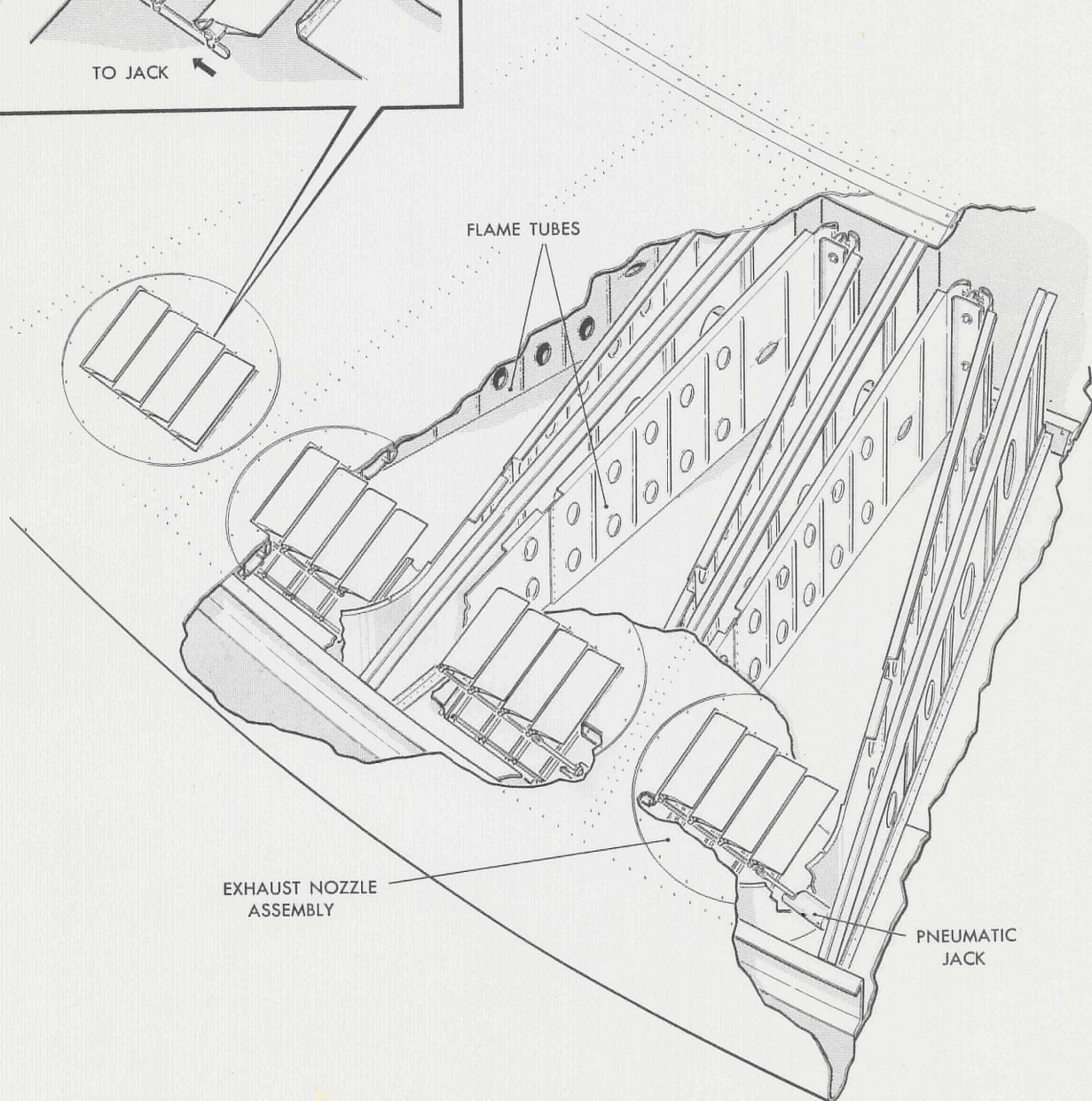
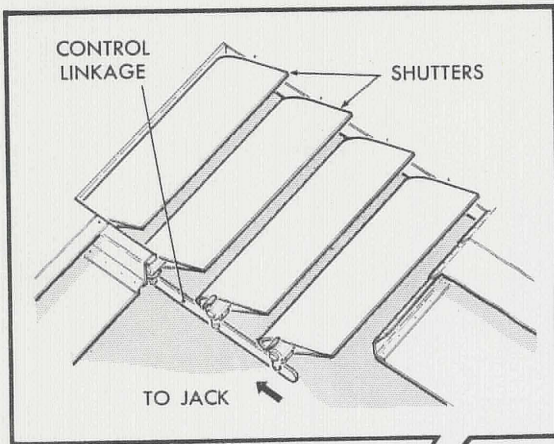
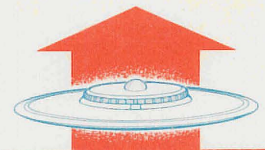

FIG. 5 FLAME TUBE AND FINAL NOZZLE ASSEMBLY

2138-1794-1

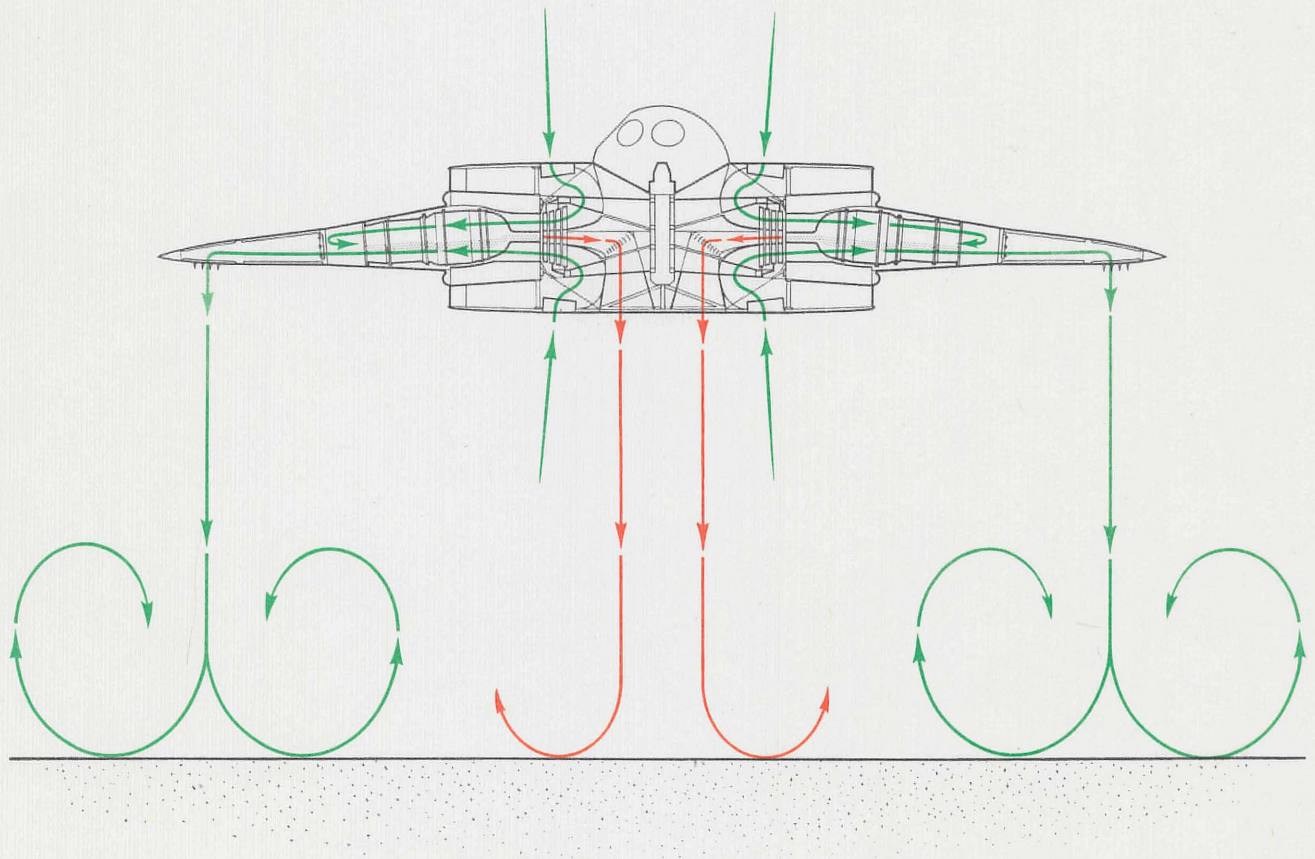

FIG. 6 FLOW DISTRIBUTION - HOVERING AND GROUND CUSHION



In forward flight ram pressure is collected into the air intake, which progressively increases the afterburning pressure ratio and thermal efficiency. For supersonic speed, augmentation will always be necessary and because of the large mass of air the impellers can handle, a very large thrust and high top speed is possible. The large installed thrust also leads to a high thrust-to-weight ratio which makes a very high ceiling possible. The efficiency of the airframe at supersonic speed appears good and that of the engine reasonable, so that a long supersonic cruise range is also forecast.

For landing, a fully vertical descent will usually be made, with or without thrust augmentation from a hot main jet. Transition to the landing condition from in-flight is similar to the take-off transition. The nose is raised and the jets transferred to the undersurface and leaned downward collectively to rapidly slow the aircraft down; as the speed falls close to zero the nose is lowered and the aircraft brought down into the ground cushion. The pilot must then close the throttle to reach the ground.

Tests completed under contract AF33(600)30161 (Supplemental Agreement No 1), have largely confirmed the performance potential and basic feasibility predicted for this new type of aircraft and confirmed Avro Aircraft Limited in their resolve to risk the building of a prototype in the shortest possible time.

The tests have also, however, inevitably shown up the need for further test work in certain areas. Additionally in this phase of work it is desirable to cover other areas not previously investigated, such as the transonic speed range and the very low speed transition regime.

Furthermore in the previous program effort was confined to design study of a research type aeroplane and it is also desirable to include study of the application of the aircraft to a weapon system in the next development phase. These considerations form the basis for the detail proposals which follow.

The work proposed is described under the following headings:

- (a) Design and performance.
- (b) Aerodynamics.

- (c) Propulsion.
- (d) Stability and control.
- (e) Structures.

Every effort has been made to outline the proposed course of work in detail. It is however likely that in the course of a twenty month program additional items not now foreseen will appear essential, and others now planned may become relatively unimportant. Any changes to the planned USAF program will be with the prior approval of the USAF and will be reported in the bi-monthly progress reports required in Section 8. These will also record any changes in the P. V. 704 program.

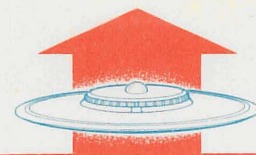
3. DESIGN AND PERFORMANCE3.1 Design Study

1.1.9

A design study will be made to apply the Avro Aircraft VTOL design concept to one of the following, whichever is considered the most suitable:

1.1.9.1

- (a) Special reconnaissance weapon system.
- (b) Interceptor weapon system.
- (c) Fighter bomber weapon system.

The study will include general assembly drawings, installation drawings for equipment and stores carried and weight and performance data with supporting information.

In addition, a general design specification for a USAF research aircraft based on P.V.704 will be submitted. MIL-D-8034 and MIL-C-5011A will be used as a guide in presenting information.

Design information will include investigation of the following:

- (a) The effect of temperatures on the structural strength and rigidity of the aircraft including the effect due to aerodynamic heating, gas generator exhaust and outer wing combustion. (It is anticipated that this will form part of the required stress analysis, the scope of which is defined in more detail in Section 7 of this program). 1.1.9.2
- (b) Crew escape procedures and systems. 1.1.9.3
- (c) The ground handling requirements of the aircraft including take-off and landing surface requirements. 1.1.9.4
- (d) The range of fuel stowage compartment temperatures, and the provision of suitable stowage conditions. 1.1.9.5
- (e) Cooling and pressurization requirements of crew equipment and structure. 1.1.9.6

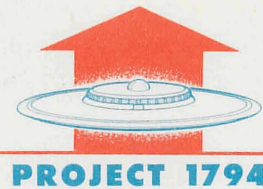

Statement
of Work
Sub Parts
1.1.9.7

- (f) Performance trade data for the aircraft in respect of such items as range, payload, ceiling, maximum speed, etc.

It is generally understood that only information relevant to design proposals will be presented, whether for components, sub systems, or any other items; comprising a list of equipment with description and artist's conception drawings. Performance or design specifications for any new suggested items of equipment will not be included. It is, however, understood that the design study for the weapon system will include a model specification to the format outlined in specification MIL-I-6252, to the extent called for in MIL-D-8034.

It is visualized that drawings will be provided approximately as follows:

- (1) A three-view general arrangement of the complete aircraft, tabling its leading particulars and a numerical list of the subsidiary study drawings.
- (2) A three-view arrangement containing an inboard profile of the aircraft, a diagram of the component breakdown, and a diagram illustrating internal flow of gases.
- (3) A geometry drawing of the complete aircraft defining major dimensions and wing profile.
- (4) Drawings of the cockpit arrangement showing pilot's equipment and furnishings, instrument panels and consoles, aircraft and power plant controls, navigation and communications equipment, crew entrance and escape, cooling and pressurization equipment.
- (5) Drawings of the engine installation showing air intake and gas exhaust system, auxiliaries gear-box arrangement, controls and services provisions.
- (6) A drawing of the central turbine-compressor showing main shaft and bearings, fixed and

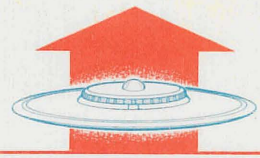

rotating structures, typical ring and blade assemblies with adjacent stators and seals, and lubrication system.

- (7) A drawing of the centre aircraft structure showing integral fuel tank and mid wing assembly, including alighting gear and its attachments.
- (8) A drawing of the aircraft outer wing structure showing installation of combustor cans and accessories together with hot gas exhaust shutters.
- (9) A drawing of the aircraft upper and lower intake structure showing ramp and entry arrangement, hovering doors, internal vanes and cascades.
- (10) A diagram of the aircraft control system depicting the pilot's central control valve, trim and hovering valves, shutter valves and jacks, afterburner valves, and associated pneumatic systems.
- (11) A diagram of the aircraft fuel system depicting tank pressurization, tank interconnects and vents, fuel filling arrangements, anti G provisions, supply to engines and combustor systems.
- (12) Drawings showing ground handling arrangements including removable cowlings and access doors, engine replacement, turbine-compressor removal, aircraft towing picketing and hoisting attachments, external charging connections.
- (13) A diagram showing electrical power source and services, and tabling a preliminary power load analysis.
- (14) Drawings showing armament and/or reconnaissance equipment installations together with associated electronic equipment.

Design information as required by MIL-D-8034 will also include the following items:

- (1) Plot of centre of gravity travel and analysis of effects.

- (2) Group Weight statement in accordance with form AN9103 and substantiating data.
- (3) V-n diagram with gust considerations in accordance with MIL-S-5702.

In presenting performance information for the weapon system design study the requirements of specification MIL-C-5011A will be followed.

In connection with performance prediction however it may be noted here that there are special problems associated with the particular aircraft configuration proposed. It is usual to predict the performance of an aircraft from estimates of thrust and drag which are obtained separately on the assumption that thrust has little or no influence on drag or trim requirements. In the case of Project 1794 this assumption cannot be justified, partly on account of jet interference effects and partly on account of the relation between trim requirements and jet deflection. The precise meaning of thrust and drag becomes somewhat obscure and wind tunnel tests provide values of net propulsive force (thrust minus drag).

The required analyses of performance may then be based either on an arbitrary separation of thrust and drag, which provides to some extent for the effects of interference and trim requirements, or on very extensive wind tunnel tests designed to provide values of net propulsive force for a wide variation in jet coefficient, jet control parameter and intake mass flow. It is anticipated that a combination of both methods will be employed in performance prediction for the above studies, to obtain performance data over the entire range of speed and height. Take-off and transition performance is a special case to which the above remarks also apply - but consideration must be given in addition, to the aerodynamic characteristics with various transition control positions. The basis of performance prediction will form part of the substantiating data report required by MIL-C-5011A.

The following specific items will also form part of the substantiating data report:

- (1) Plot of area distribution cut at Mach 1.0.
- (2) Tabulation of wetted areas.

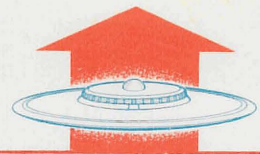

- (3) Zero lift drag build-up, components and total.
- (4) Plot of dC_D/dC_L^2 vs. Mach No.
- (5) Plot of aerodynamic centre travel vs. Mach No.
- (6) Variation of $dC_L/d\alpha$ vs. Mach No.
- (7) Low speed aeroplane efficiency factor 'e'.
- (8) Substantiation of drag factors and thrust.
- (9) Take-off, landing and transition calculations.
- (10) Plot of L/D max and Mach No.
- (11) Plot of C/L optimum and C_L actual vs Mach No. } *new*
- (12) Plots of L/D vs C/L.

Performance information as required by MIL-C-5011A will include the applicable mission profiles showing altitude vs. distance.

3.2 Prototype P.V. 704 Design

The prototype P.V. 704 design was started in December 1955 with the design of the basic structure and powerplant installation for first test of the propulsion unit, as described in Section 4. For prototype completion to the tethered test stage the other major items are the outer wing, the cockpit and flight test instrumentation and a tethering rig, the latter probably consisting mainly of a large crane.

The design of the basic structure and propulsion unit is now substantially complete and it is expected that the additional items together with all preliminary modifications to the rig design required by the prototype will be completed in July 1957.

3.3 Work Chart Scheduling and Cost

A chart illustrating the work content in the design and performance group is presented in Fig. 7. It will be appreciated that the scheduling for this work, as shown on the following page in Fig. 8 is contingent upon the completion of design for test, items required by certain fixed dates (now tentatively suggested). Cost and manhour estimates are shown on pages 95-108.

2234-1794-1

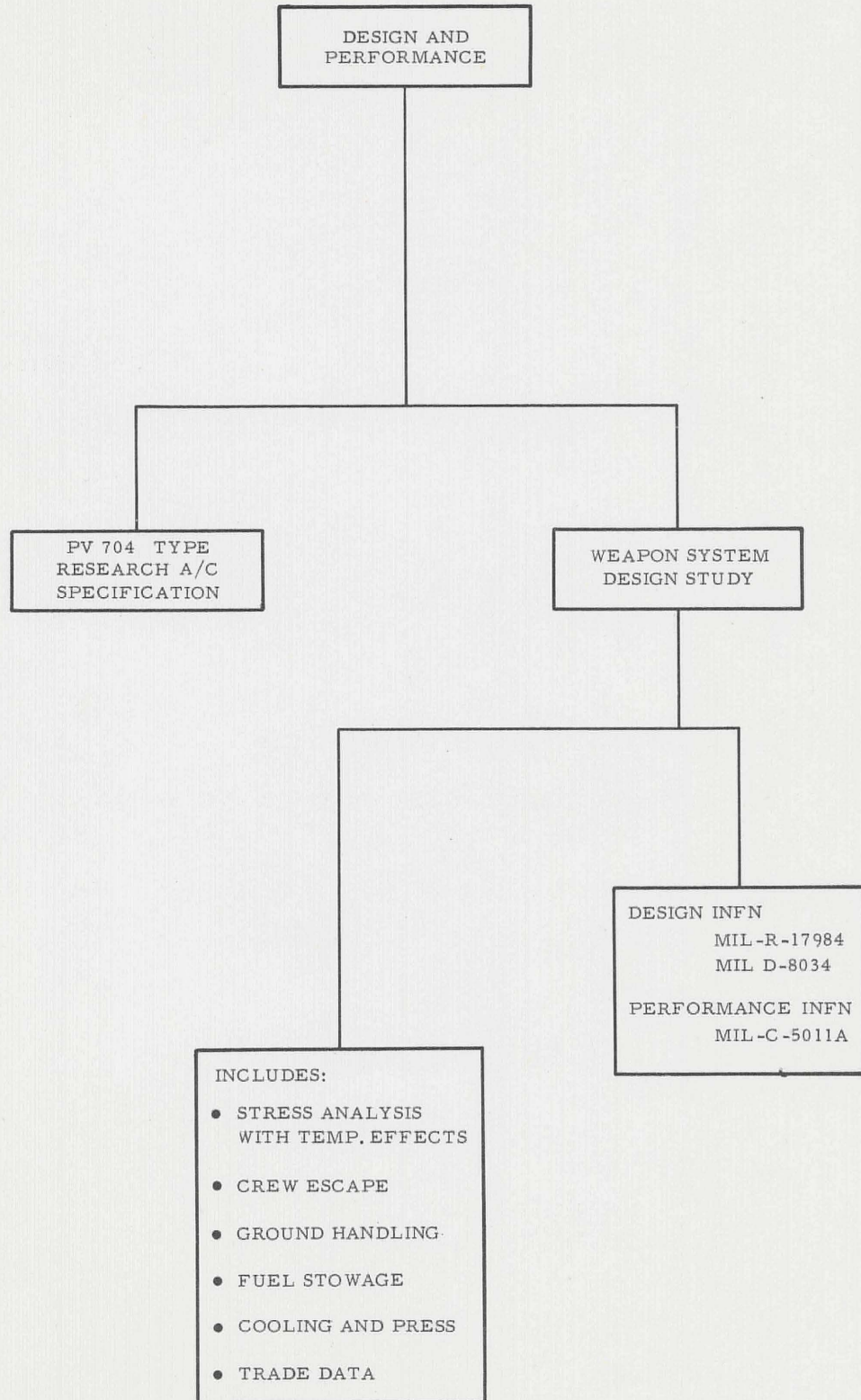

FIG. 7 WORK CHART-DESIGN AND PERFORMANCE

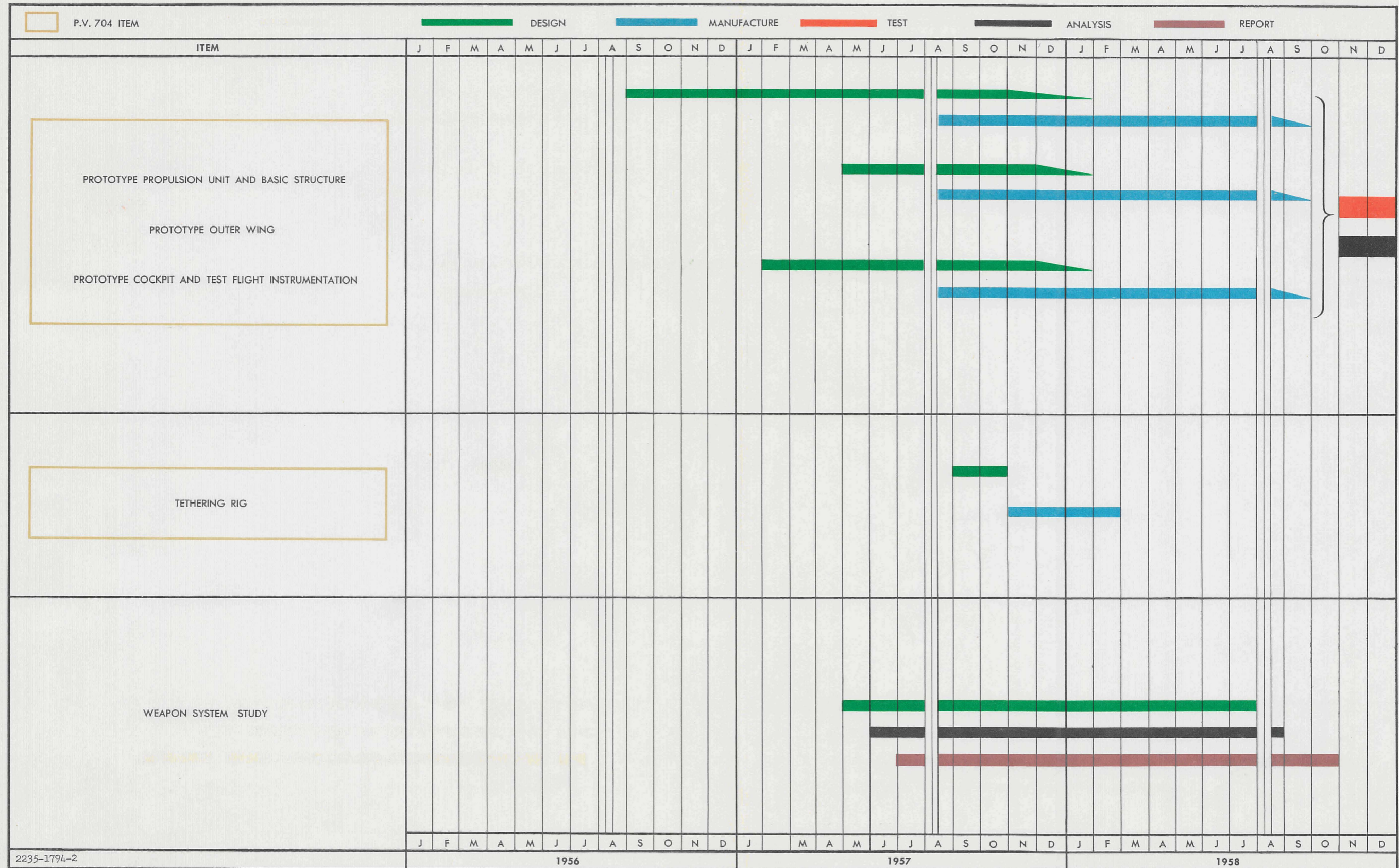
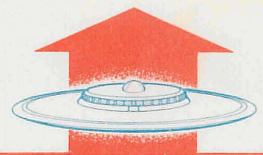

FIG. 8 WORK SCHEDULE CHART-DESIGN AND PERFORMANCE

727-1794-1



4. AERODYNAMICS

4.1 Prototype Weight and Load Analysis

Prototype P. V. 704 weight and load analyses are presently being carried on and will form part of the research aircraft specification required by the USAF under Section 3.

4.2 Wind Tunnel Tests

To supplement and extend the range of the results of the wind tunnel tests carried out under the terms of the previous contract, it is proposed to carry out a further series of tests through the whole speed range. Past experience will prove useful in determining the ranges of the various test parameters required more exactly, and will serve to provide models and test equipment of higher standards.

4.2.1 Hovering and Transition Tests

1.1.4

A number of hovering and transition tests have already been carried out on the 1/6th scale subsonic model. However, in view of the 'hysteresis' encountered, the validity of using a reflection plane model for tests of this nature is subject to considerable doubt. A new hovering and transition model is, therefore, proposed; to employ the same air supply and evacuation system as was used for the 1/6th scale model referred to above. Fig. 11 showing an early scheme is included to illustrate the general method, although this scheme has been superseded by an alternative which gives a symmetrical travel flow.

In this type of model the intake and exhaust air has to pass through the strut, thereby making it uncommonly large and the main objection to such models is the consequent large strut interference. At very low speeds where the aerodynamic drag is of relatively small importance, this objection becomes less pertinent and the use of such models more attractive. However, to keep the size of the mounting and supply pipe to reasonable proportions, it is proposed to confine the intake flow simulation to the lower intake only, particularly as it has been found from the 1/6th scale model tests that the effects of the intake in forward flight are small.

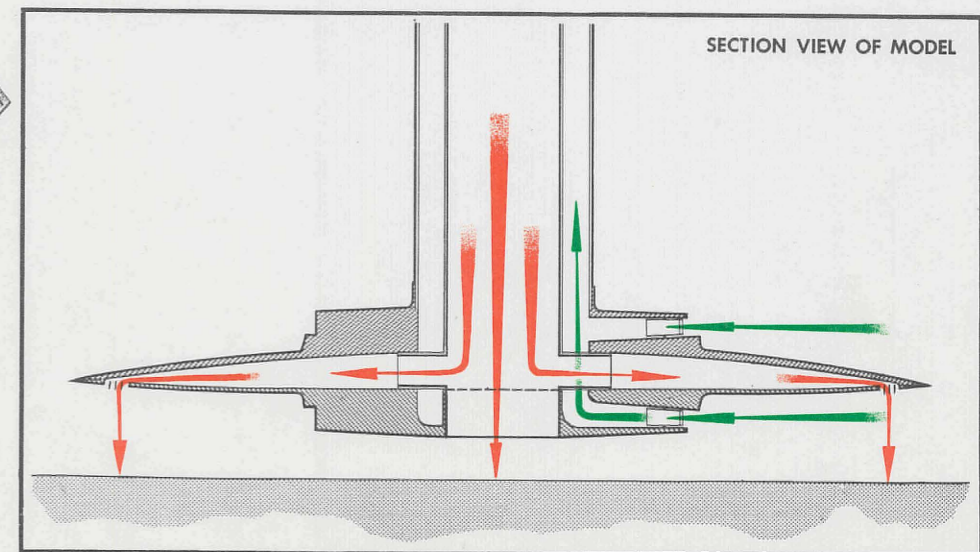
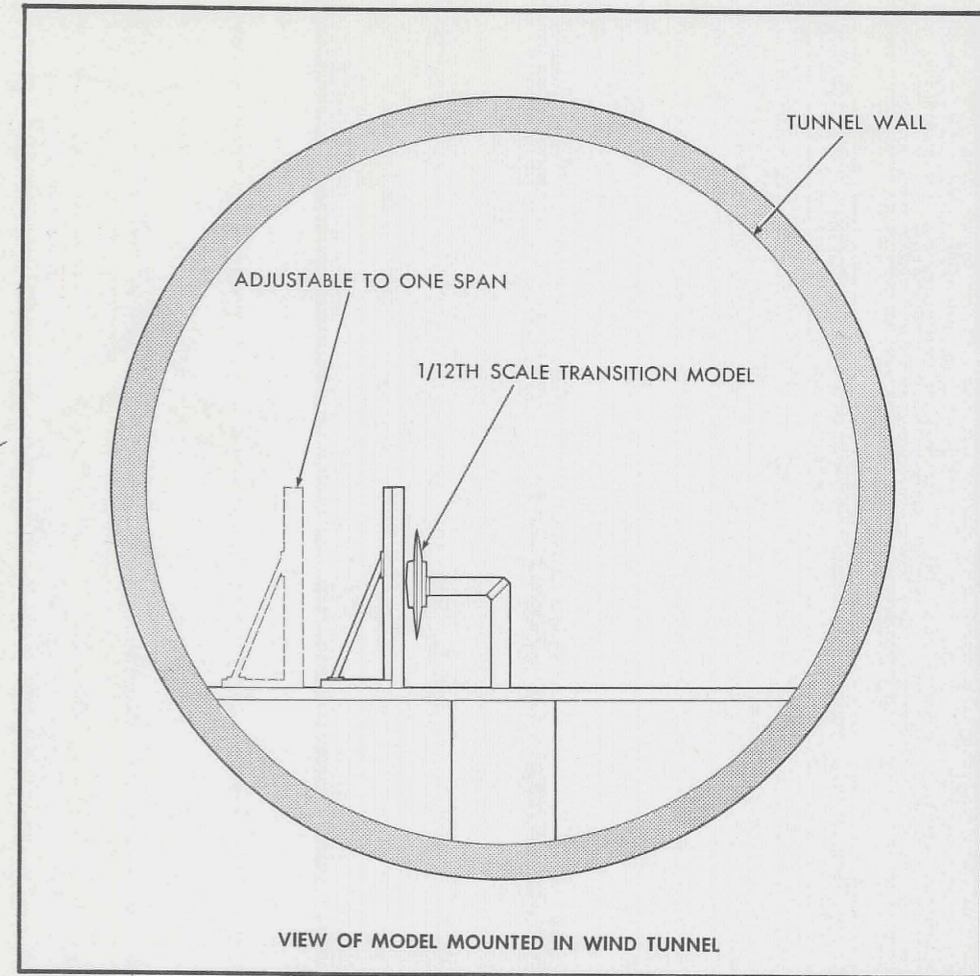
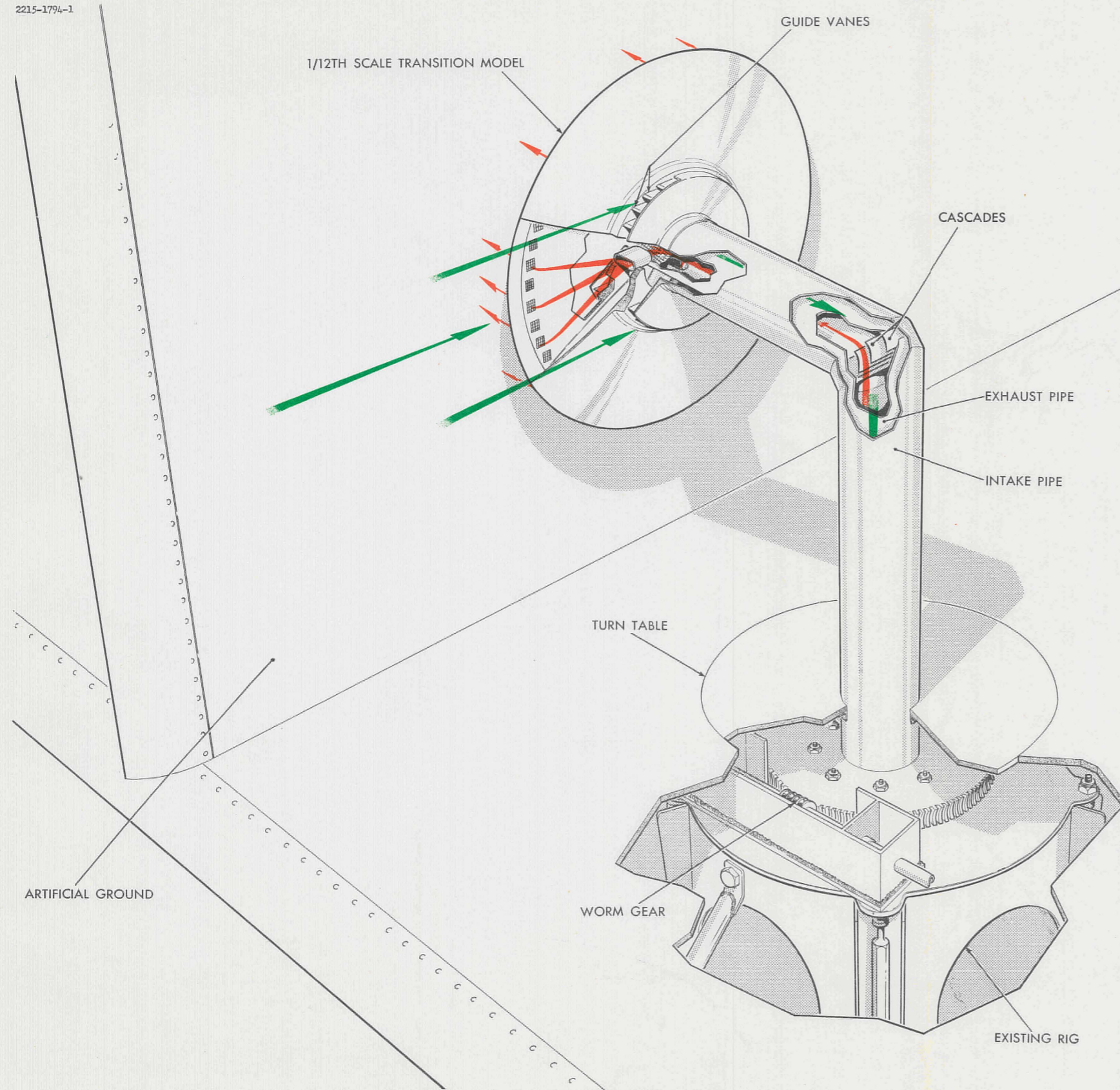
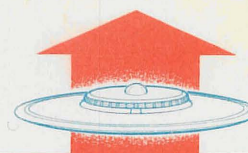

FIG. 11 PROPOSED 1/12TH SCALE TRANSITION MODEL



The scale suggested is 1/12th, and since this is a complete model, approximately half the air supply used on the 1/6th scale model will be required. Furthermore the reduced scale is an advantage from the point of view of minimizing tunnel boundary effects and it is in the transition regime where these are likely to be of consequence. This consideration was limiting as to the lowest speed used in the previous tests and with the smaller model it will, in general, be desirable to test to considerable lower tunnel velocities than were used in the previous program. Also some important extensions to the hovering tests, particularly with control in the presence of the ground, are known to be required.

Finally, it is desirable to carry out a few comparative tests on the 1/6th scale model and this is proposed as part of a further series of tests on the latter as outlined in the next section.

4.2.2 Subsonic Wind Tunnel Tests

1.1.3

It is proposed to carry out a further series of tests on the 1/6th scale reflection plane model, the principal purpose of which being to measure the wing surface pressure distribution in various conditions. This will require the installation of a large number of static orifices on the model wing surfaces. The model and installation is illustrated by the photograph of Fig. 12 and the schematic perspective of Fig. 13.

It is also considered desirable to conduct over-lapping tests with the transition model as explained in the previous section and it is believed that valuable results with regard to subsonic drag and more particularly the effect of jet displacement on the aerodynamic characteristics of the aircraft can be obtained with a moderate expenditure of tunnel time.

It is thought that most of the existing shortcomings of the balance, and of the air supply and evacuation systems can be eliminated and it is hoped that a sealed balance, eliminating the so-called air bearing, can be made to give a satisfactory calibration.

4.2.3 Transonic Wind Tunnel Tests

1.1.2

Wind tunnel force measurements on the configuration have

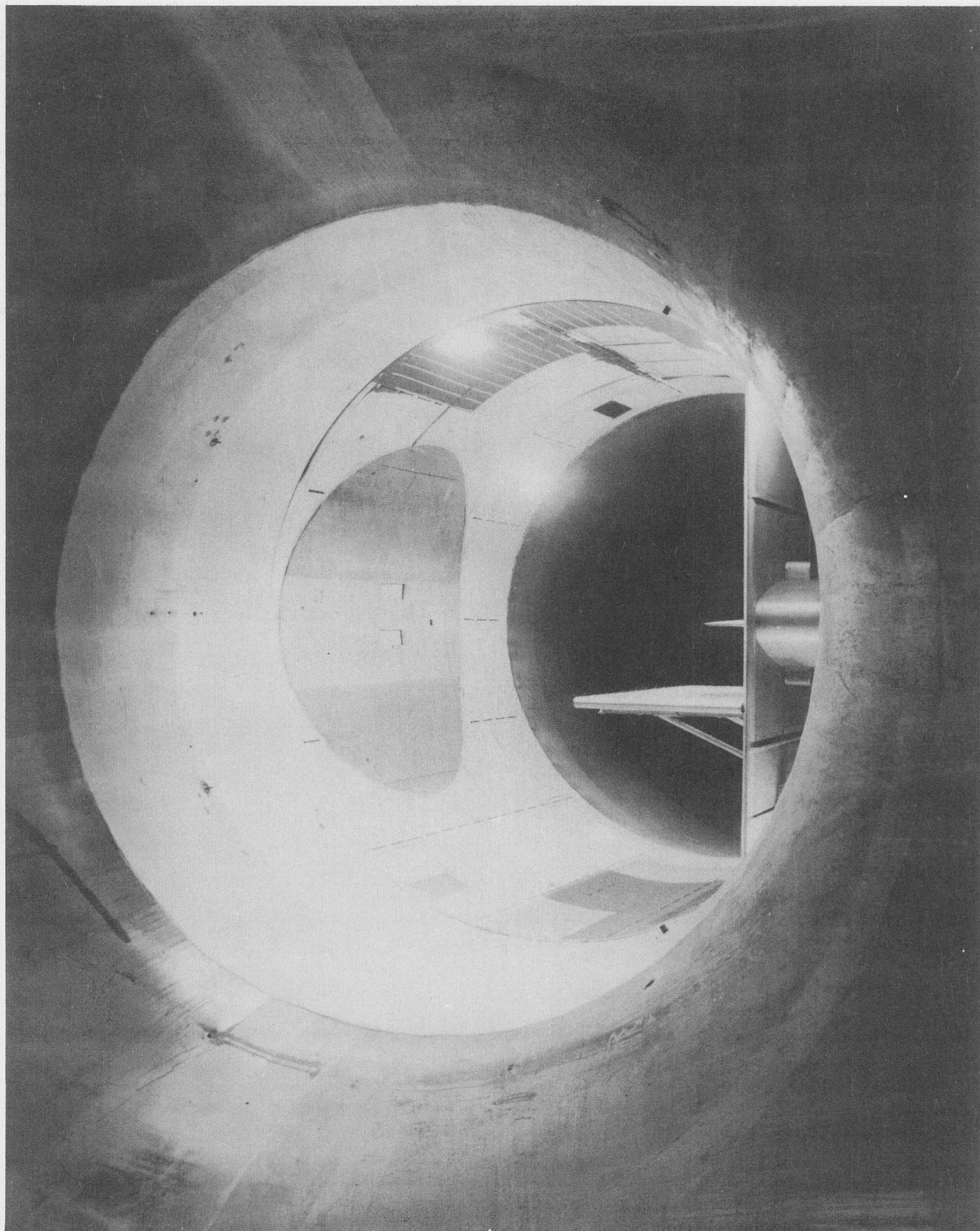
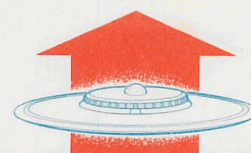

FIG. 12 1/6 SCALE MODEL IN TUNNEL

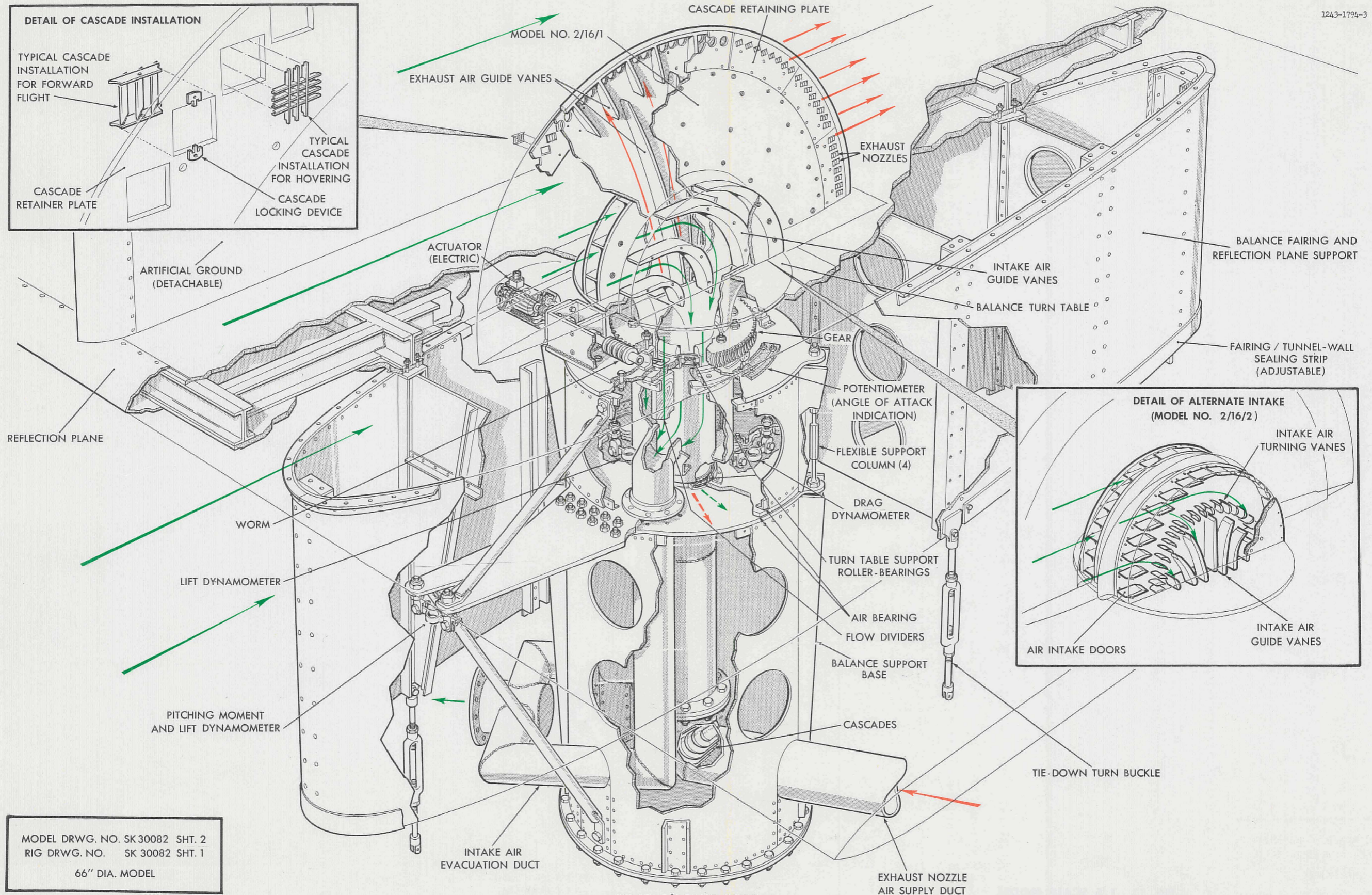
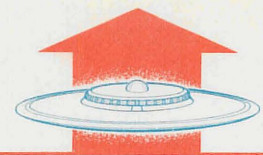

FIG. 13 1/6 SCALE MODEL

SECRET

MODEL DRWG. NO. SK 30082 SHT. 2
 RIG DRWG. NO. SK 30082 SHT. 1
 66" DIA. MODEL

727-1794-1

Statement
of Work
Sub Parts

so far been confined to the subsonic speed range and to supersonic speeds between Mach 1.5 and Mach 3. Transonic tests are considered essential in the next phase of work, particularly in view of the fact that the thrust drag margin is calculated to be at a minimum in this regime. A 1/12th scale reflection plane force model with fully simulated intake and jet flow is therefore proposed, similar to the 1/6th scale subsonic model and 1/23rd scale supersonic models already tested; predicated upon the use of the 10 ft. diameter tunnel at WADC. It is intended to obtain stability and control as well as performance data, and the similarity in basic requirements of this and previous models will make the experience gained invaluable in obtaining accurate and reliable instrumentation.

A preliminary drawing showing a tentative scheme for the installation of this model is given in Fig. 14. Tunnel scavenge air will be used to supply the jet flow and the scavenge system is expected to be able to absorb that of the intake. With the tunnel operating at a stagnation pressure of half an atmosphere it is believed that the full scale aircraft flows can be simulated satisfactorily.

It is also planned to obtain transonic component drag data from a 1/40th scale sting mounted model in the Naval Supersonic Laboratory at Massachusetts Institute of Technology, as more fully explained in the next section.

4.2.4 Supersonic Wind Tunnel Tests

1.1.1

It is proposed to re-test the three supersonic models already tested at M. I. T. with suitable improvements, as follows:

4.2.4.1 Air Intake Pressure Recovery Model

It is proposed to re-test the 1/12.5 scale reflection plane pressure recovery model at the M. I. T. with alternative improved designs of air entry. The objectives are to improve the boundary layer bleed by undercutting the ramp and to alter the design of entry lip and diffuser to prevent separation inside the intake. Tests will be carried out to attempt to determine the relative merits of external or external-internal oblique shock configurations, (the latter being defined as having one or more oblique shocks both

2216-1794-1

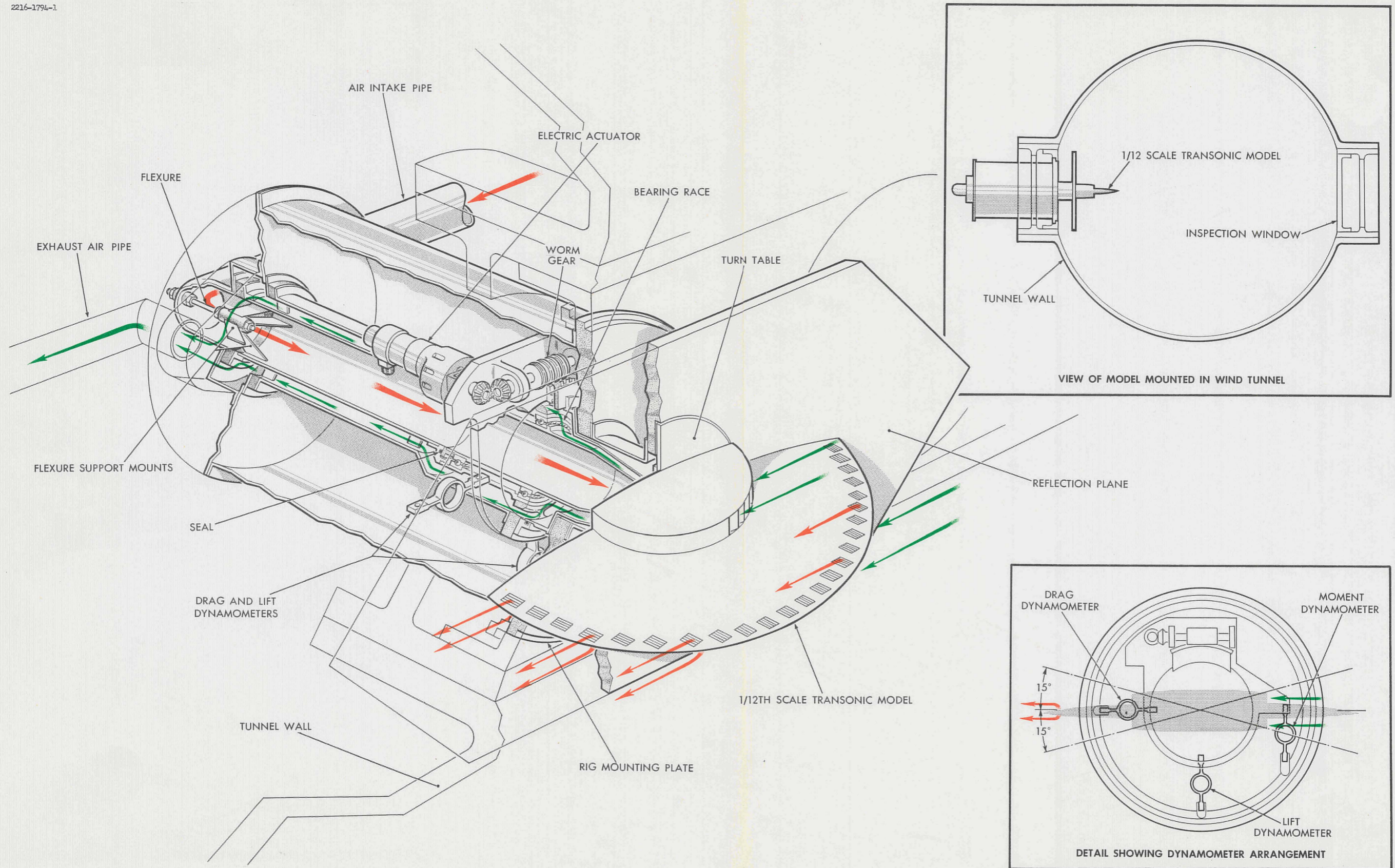
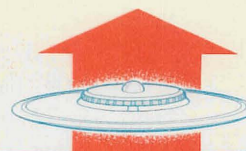

FIG. 14 PROPOSED 1/12TH SCALE TRANSONIC REFLECTION PLANE MODEL

727-1794-1



outside and inside the entry lip) from the point of view of pressure recovery. Later force tests on the 1/23rd scale model will be designed to indicate the external drag associated with these alternatives.

On this model improved instrumentation will be fitted in the exhausting duct at the rear for better determination of the mass flow, and if possible, better subsonic diffusion in the transition section from the twin air-entry ducts to the rear exhausting duct will be arranged.

This model is illustrated by the photograph of Fig. 15 and the illustration of Fig. 16 while the sketch following on Fig. 17 approximately illustrates the changes that are intended.

Since this is a reflection plane model mounted in place of one of the windows through which Schlieren photographs are normally taken, it is difficult to obtain satisfactory flow visualization. Efforts will be made to improve the optical characteristics of the reflection plane such that either satisfactory visualization with shadowgraph can be obtained or, if possible, an alternative Schlieren set-up engineered.

It is intended that tests on this model should be carried out at an early stage so that the best arrangement of air entry can be incorporated as a modification to the 1/23rd scale model for later force tests.

It is estimated that a total of approximately 36 hours tunnel time ($4\frac{1}{2}$ shifts) will be required, and no installation difficulties are foreseen.

4.2.4.2 Sting Mounted Models

The 1/40th scale model already tested, is illustrated by the photographs of Fig. 18 and 19 and the drawing of Fig. 20. As can be seen from the drawing, it can be built up in sections to obtain data on components drag, and it has no flow simulation and is thus extremely simple to construct. It is proposed, therefore, to manufacture a further model or models of this type to obtain the force increments (particularly drag) arising from thickening the wing, altering the sectional shape and modifying the intake diameter.

Schlieren photography presents no difficulty on this model and if satisfactory arrangements for shock pictures cannot

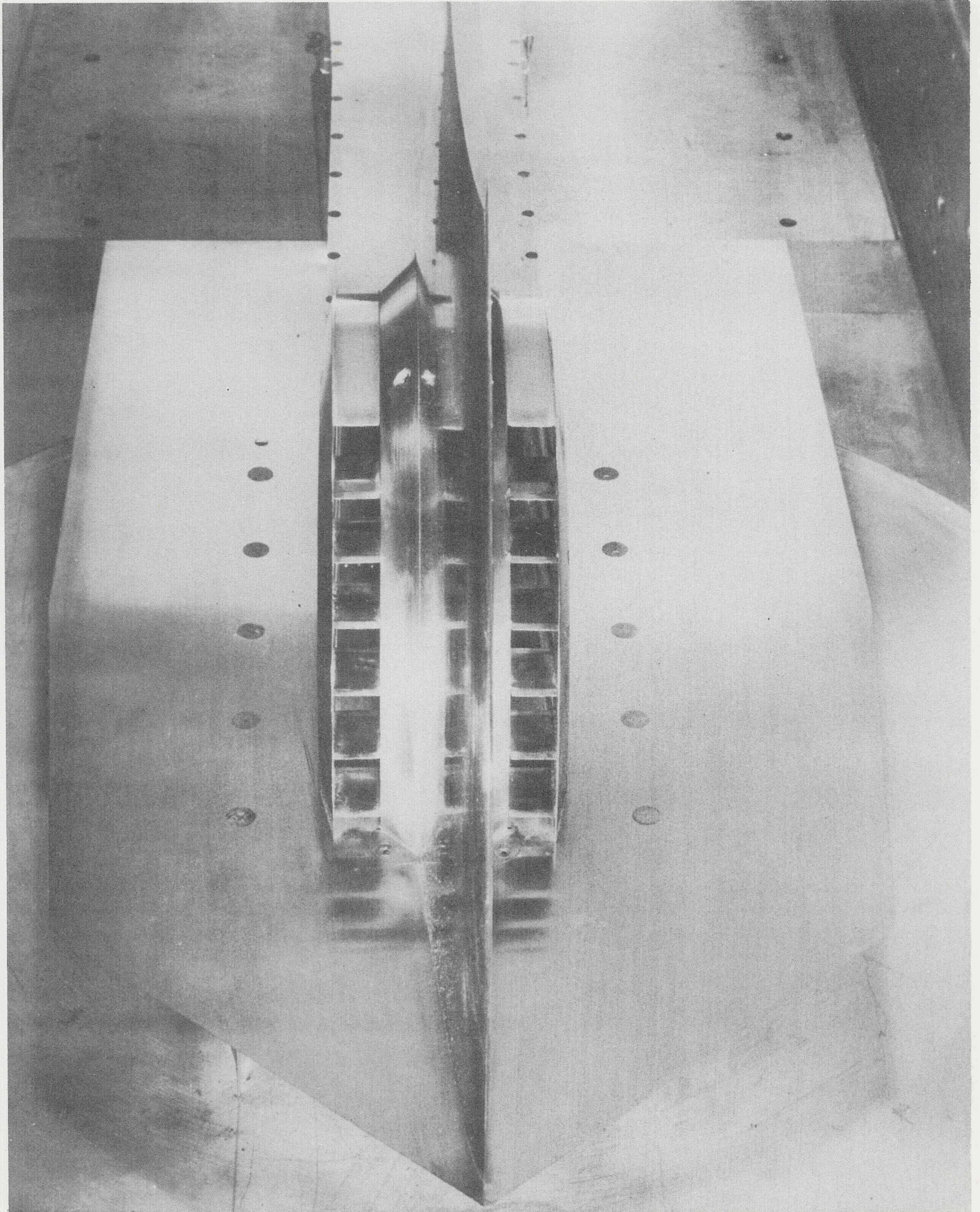
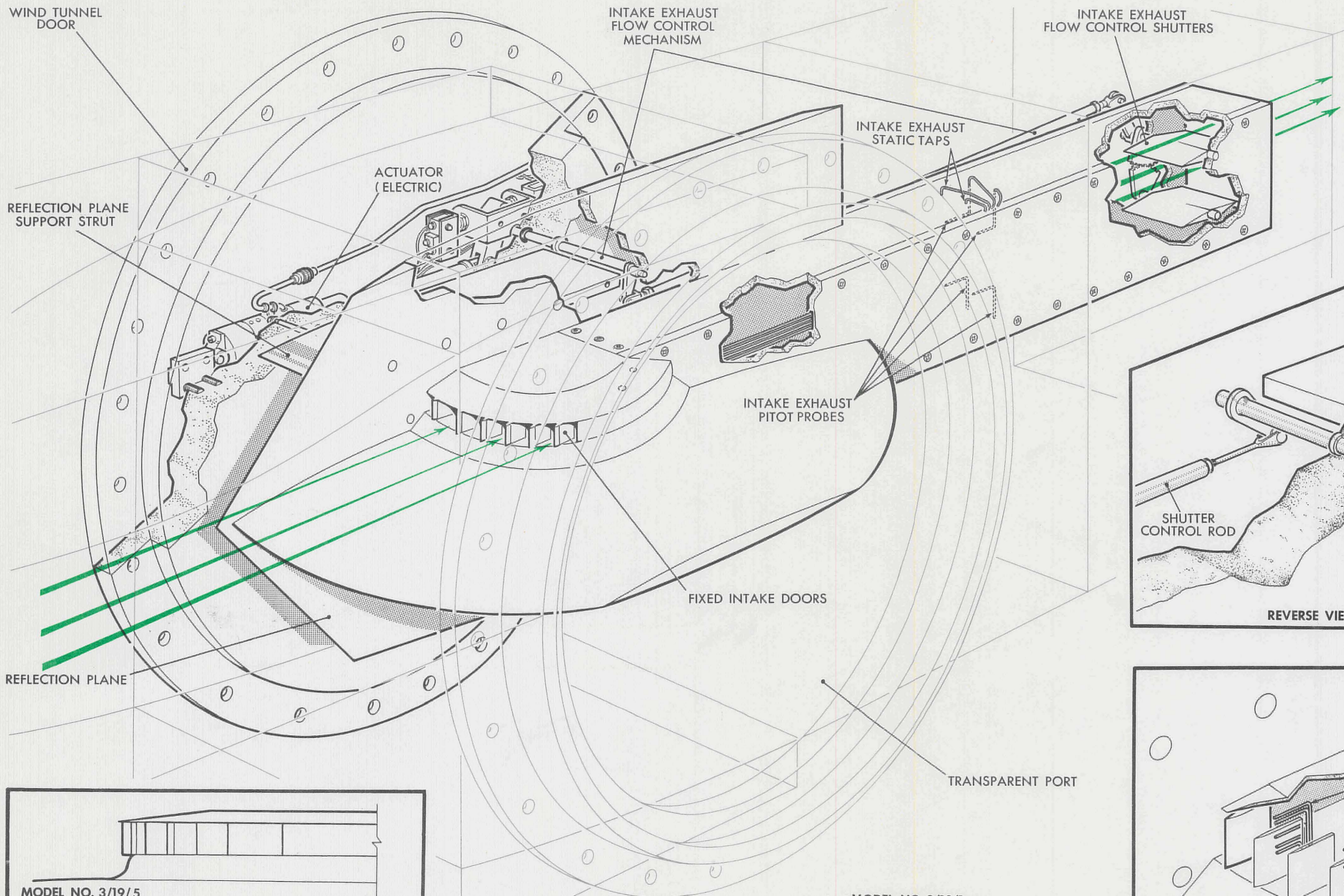
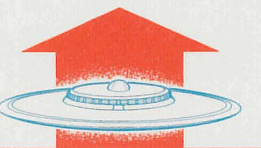

FIG. 15 2/25 SCALE AIR INTAKE MODEL



MODEL DRWG NO. SK30212 SHT. 1

| | |
|-----------------------|-------------------|
| EXTENDED ROOF | 110 & 111 SK30212 |
| CONCAVE & CONVEX RAMP | 107 & 108 SK30212 |
| EXTENDED ROOF | 10 & 11 SK30212 |
| CONCAVE RAMP | 13 & 14 SK30212 |
| NORMAL ROOF | 3 & 4 SK30212 |
| 45° RAMP | 15 & 16 SK30212 |
| 30° RAMP | 17 & 18 SK30212 |

32" DIA. MODEL

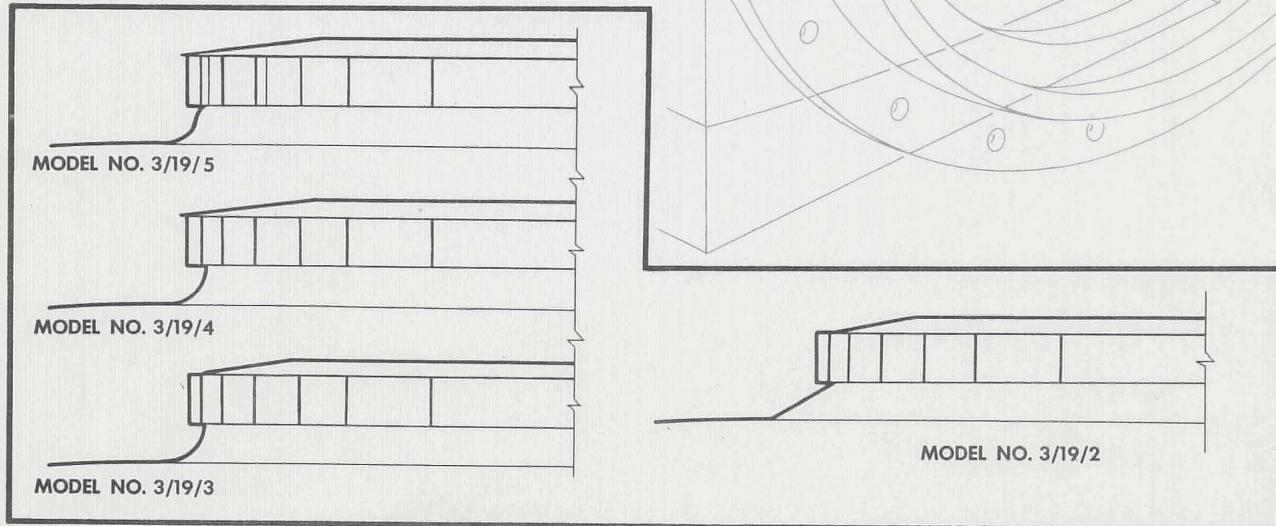
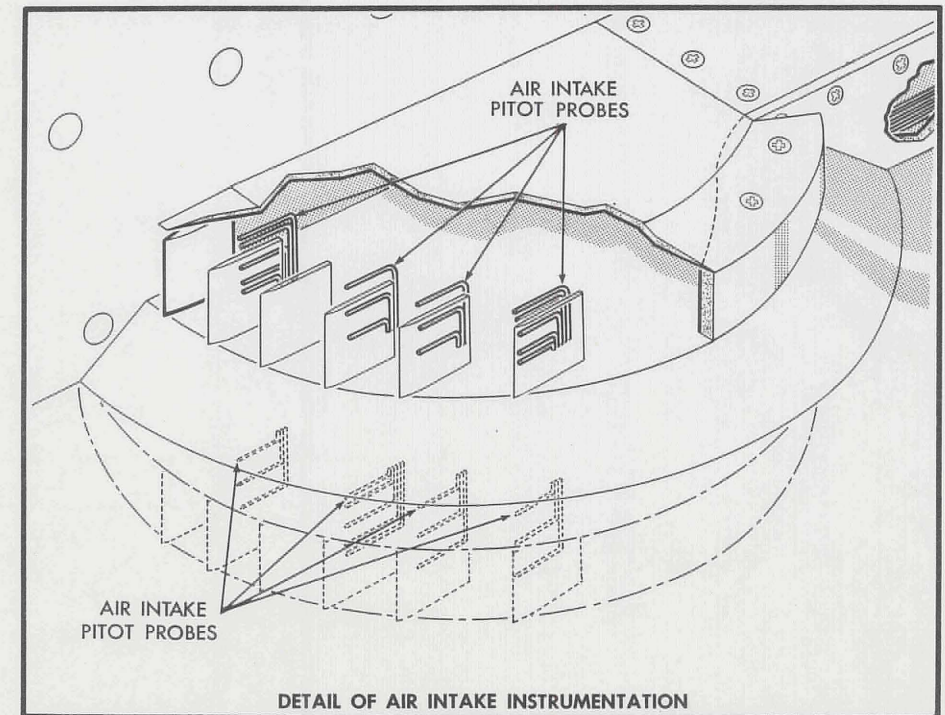
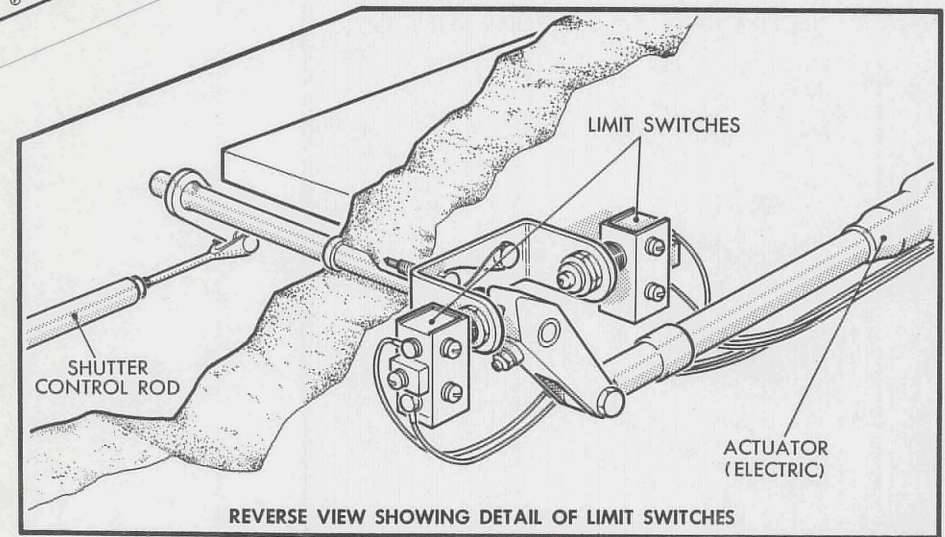

FIG. 16 2/25 SCALE AIR INTAKE MODEL

SECRET

1247-1794-2

727-1794-1

2217-1794-1

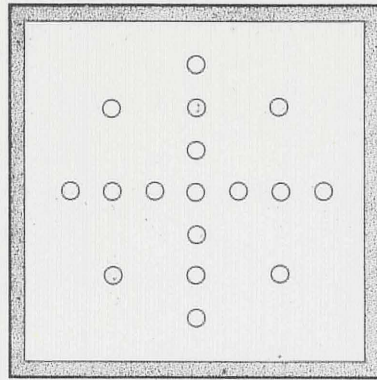

SECTION B-B
IMPROVED INSTRUMENTATION

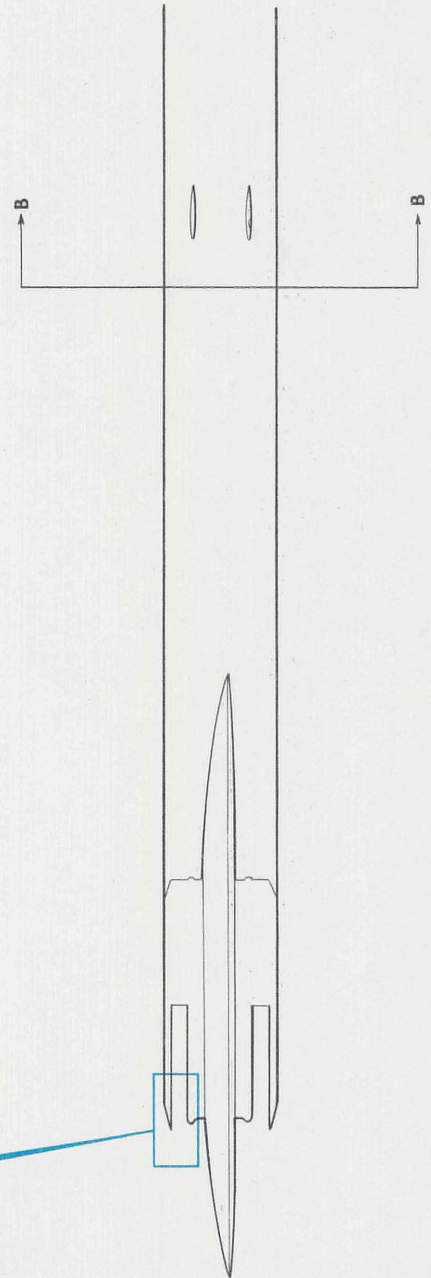
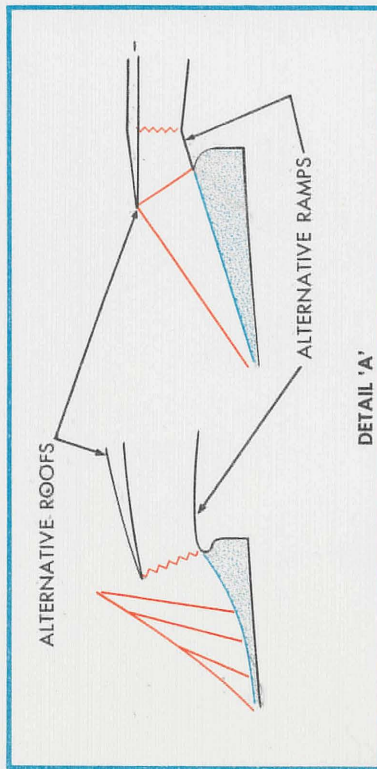

FIG. 17 PROPOSED CHANGES TO 2/25 SCALE MODEL

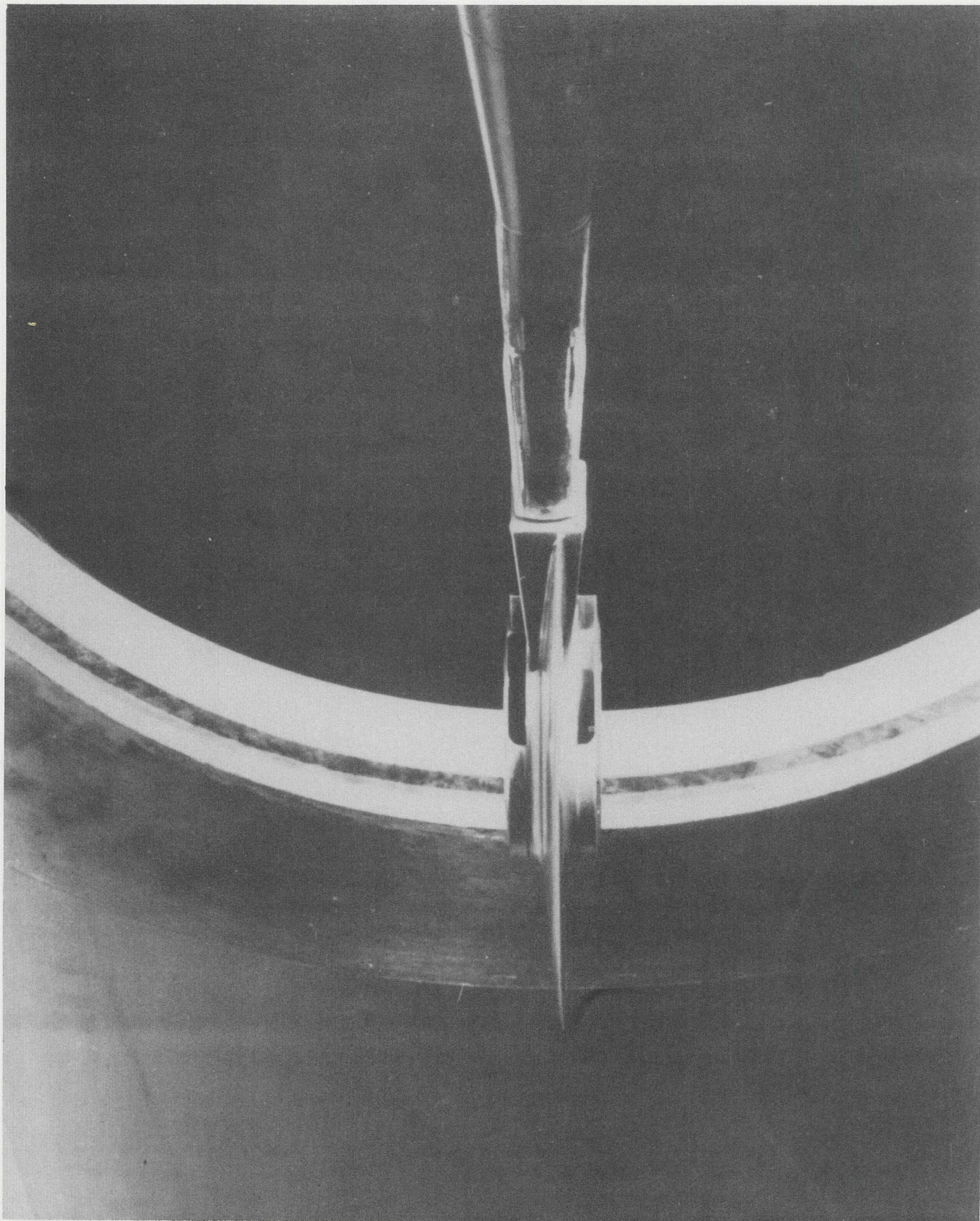
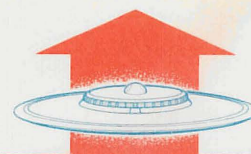

FIG. 18 1/40 SCALE STING MOUNTED MODEL

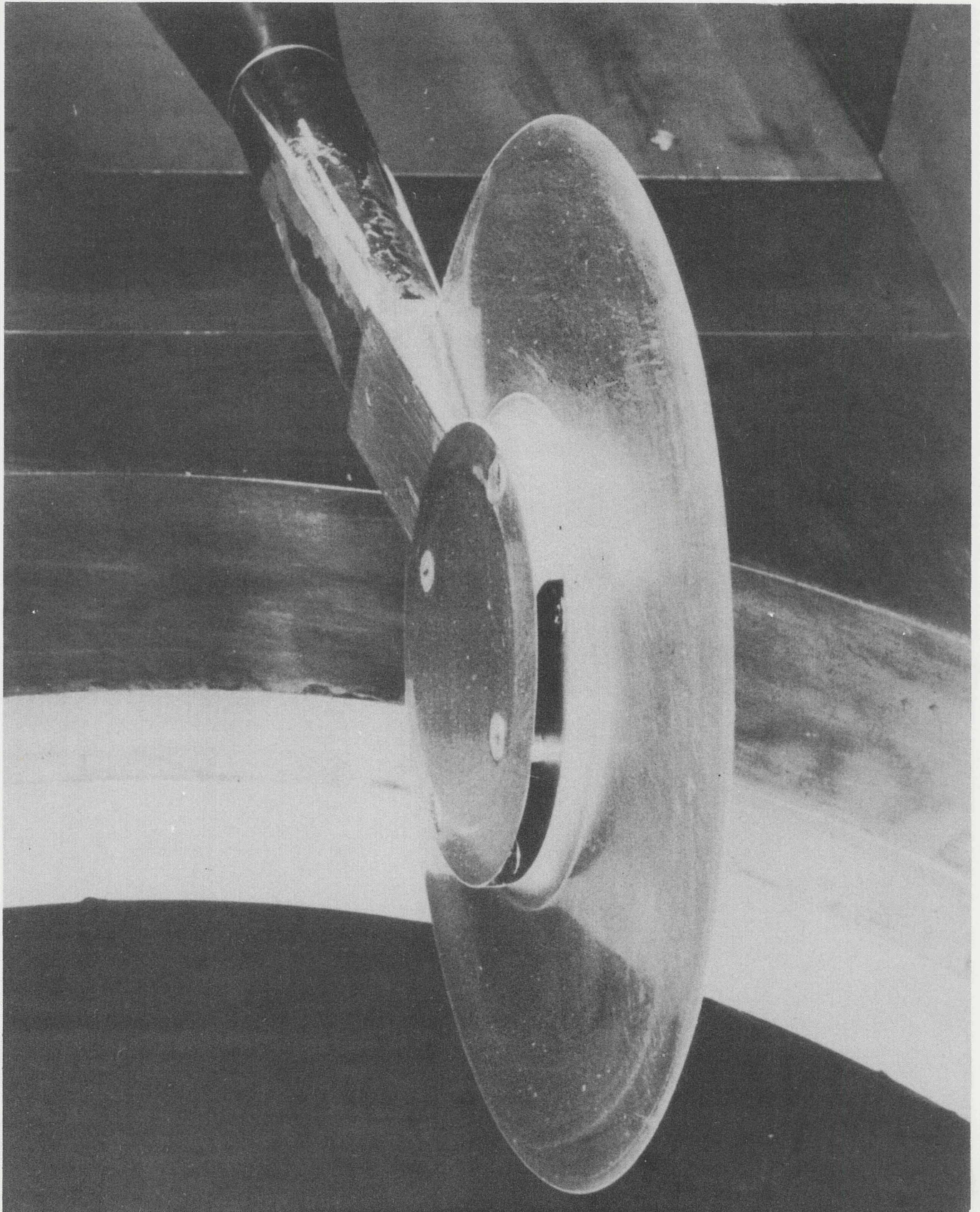

FIG. 19 1/40 SCALE STING MOUNTED MODEL



| | |
|------------------------------------|-------------|
| RIG DRWG. NO. D-1-394 AND SK 30222 | |
| WING DRWG. NO. | 13 SK 30217 |
| 45° RAMP DRWG. NO. | 5 SK 30217 |
| SOLID INTAKE DRWG. NO. | 2 SK 30217 |
| DUCTED INTAKE DRWG. NO. | 11 SK 30217 |
| 30° RAMP DRWG. NO. | 7 SK 30217 |
| 9" DIA. MODEL | |

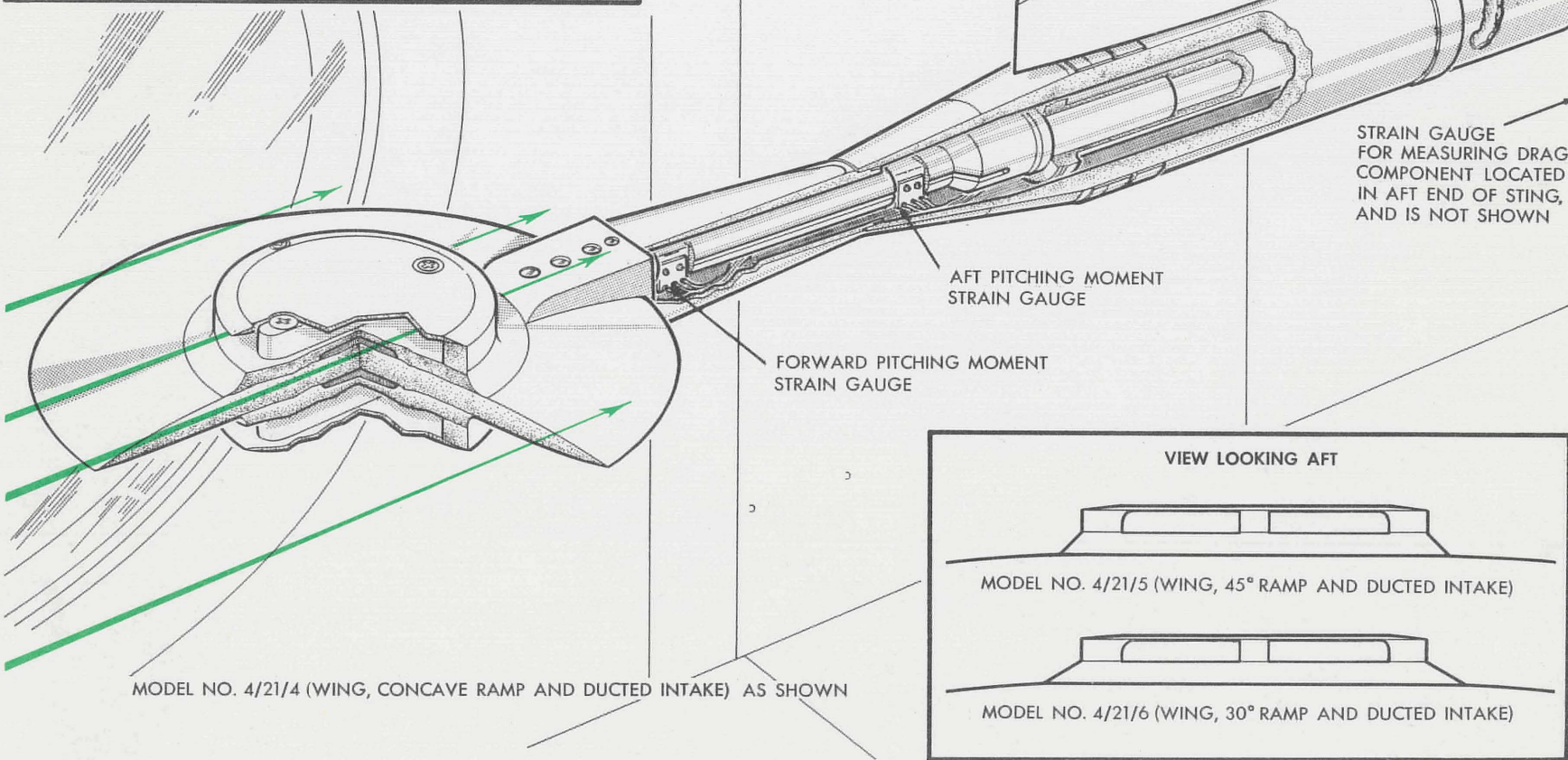
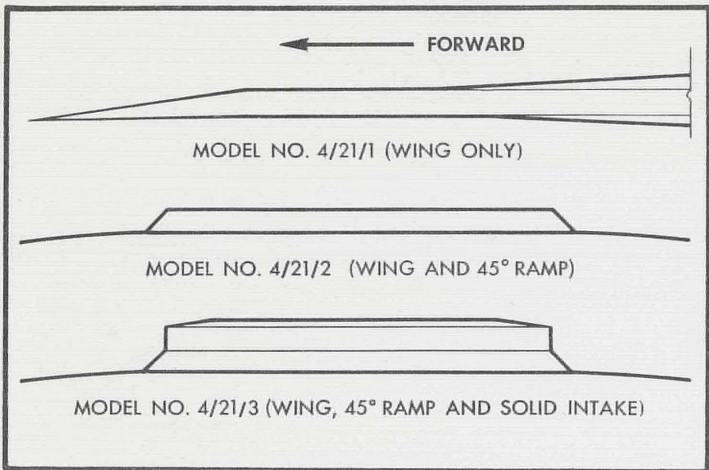
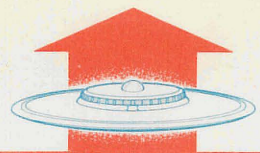

FIG. 20 1/40 SCALE STING MOUNTED MODEL

SECRET



be achieved on the pressure recovery model of paragraph 4.2.4.1, selected air intake arrangements tested on this model will be reproduced on the sting mounted model.

It is also intended to carry out transonic tests on these models (as originally programmed for the model illustrated) to obtain force correlation (particularly drag) with the transonic model now proposed for tests with flow simulation.

A balance for this model is in existence at the M. I. T. and it is expected that it will be convenient to test both this model and the pressure recovery model during the same period. It is anticipated that a total testing time of 24 hours (3 shifts) will be required for the sting mounted models.

4.2.4.3 Force Model with Flow Simulation

It is proposed to re-introduce the 1/23rd scale reflection plane force model with flow simulation into the supersonic tunnel at the Massachusetts Institute of Technology. The previous tests with this model were limited by the time available to an abbreviated program, and hampered by the lack of sufficient intake flow for proper simulation and by some instability in the model intake circuit. The latter will be corrected and it is believed that the full mass flow can now be drawn through the air intake without difficulty by using the new suction pump capacity recently installed at the M. I. T. instead of, as before, feeding the air intake flow back into the wind tunnel downstream of the working section. The existing model and balance system is shown in the photograph of Fig. 21 and the schematic perspective of Fig. 22.

It is proposed to extend the scope of the future series by allowing for a greater Mach No. coverage to include up to Mach 4.

Momentum drag and thrust polars will be taken more often and over a greater range than before. As explained in paragraph 4.2.4.1, the air entry will be re-designed to correspond to the best obtained from the pressure recovery model.

It is hoped that the so-called air bearings can be eliminated from this balance also, which will allow the measuring accuracy of the instrumentation for air flow measurement to be vastly improved. Proposed changes to the model are illustrated by the sketches on Fig. 23.

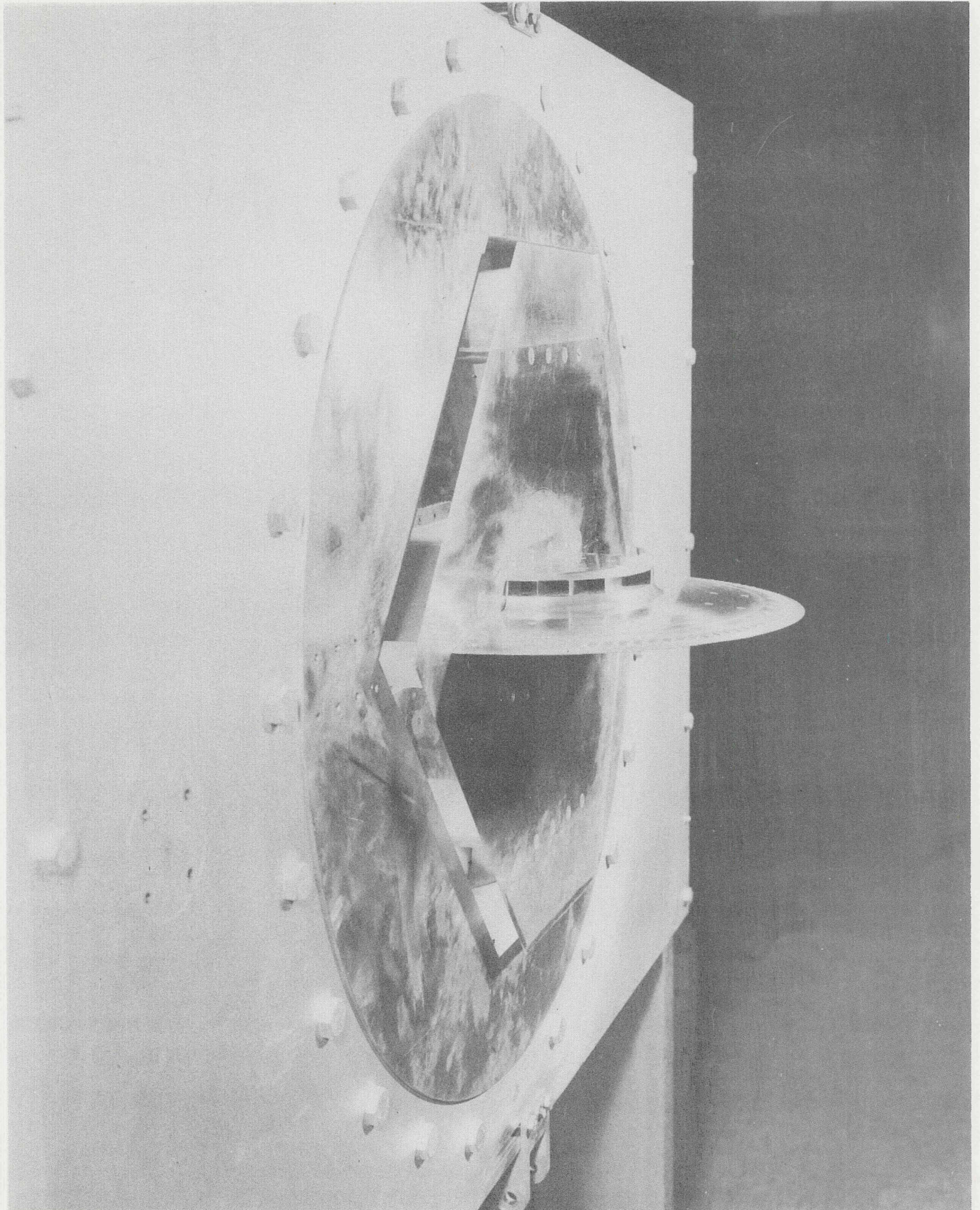
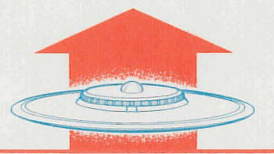
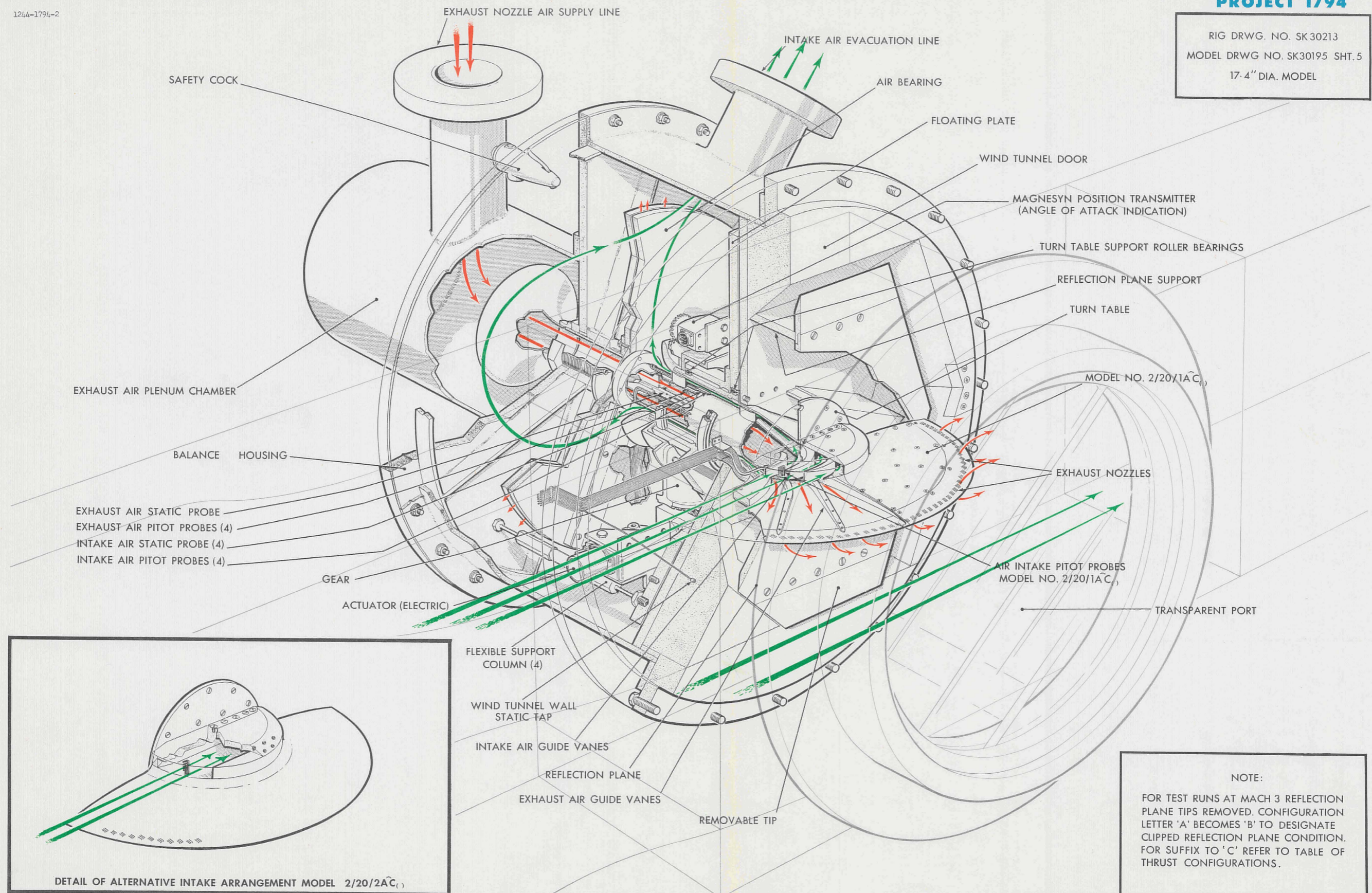

FIG. 21 1/23 SCALE SUPERSONIC MODEL



RIG DRWG. NO. SK30213
 MODEL DRWG NO. SK30195 SHT.5
 17.4" DIA. MODEL



NOTE:
 FOR TEST RUNS AT MACH 3 REFLECTION
 PLANE TIPS REMOVED. CONFIGURATION
 LETTER 'A' BECOMES 'B' TO DESIGNATE
 CLIPPED REFLECTION PLANE CONDITION.
 FOR SUFFIX TO 'C' REFER TO TABLE OF
 THRUST CONFIGURATIONS.

FIG. 22 1/23 SCALE SUPERSONIC MODEL

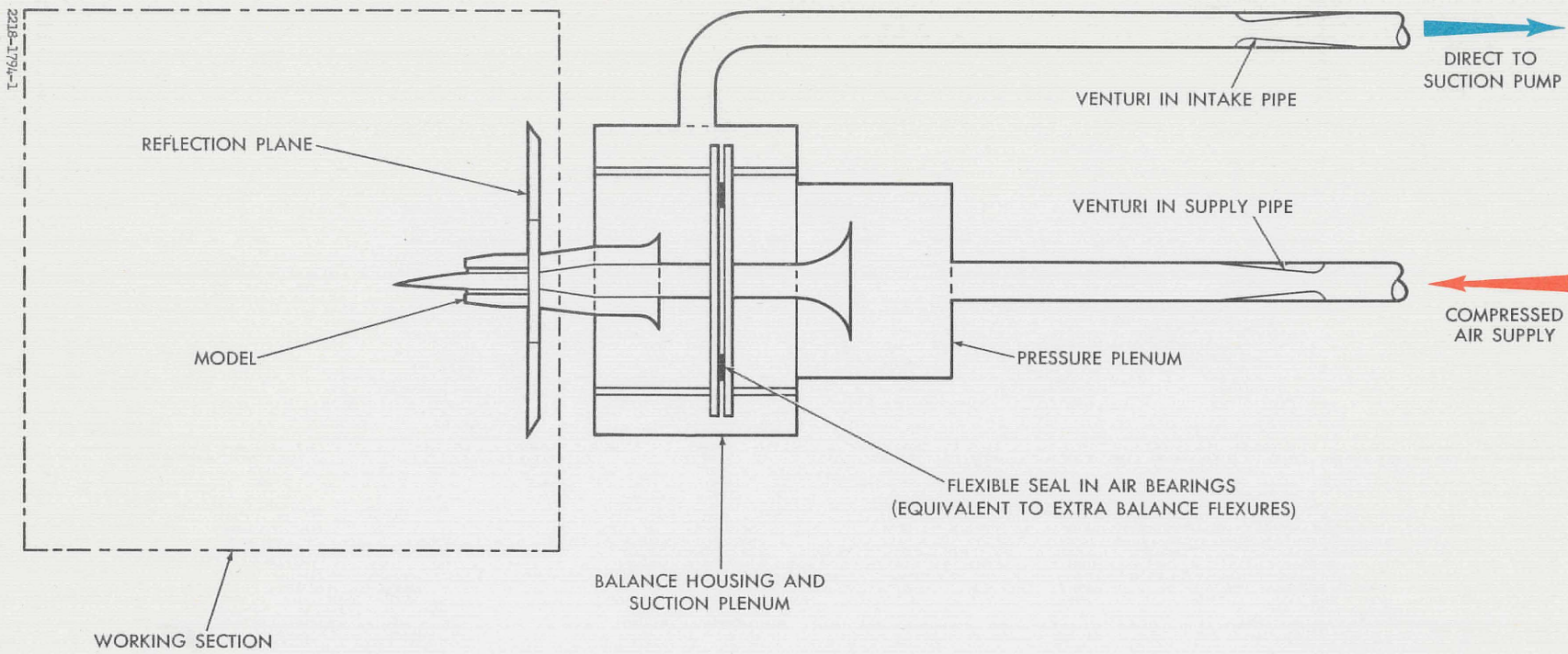
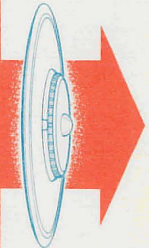
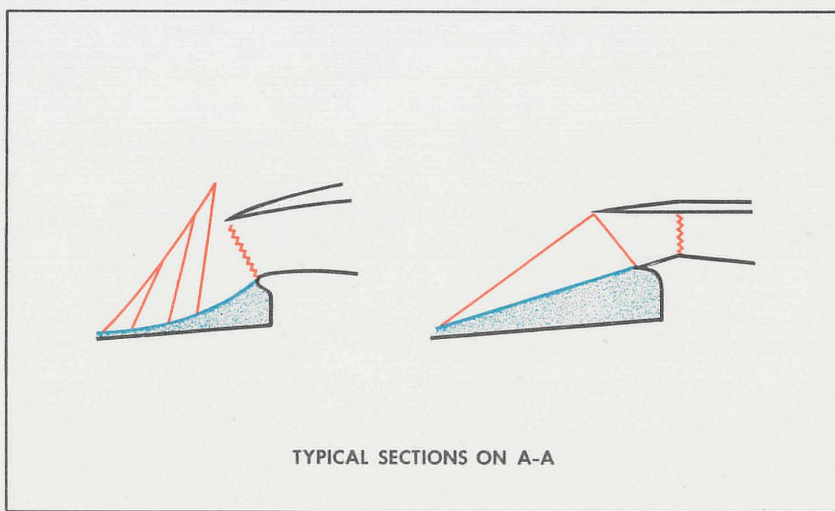
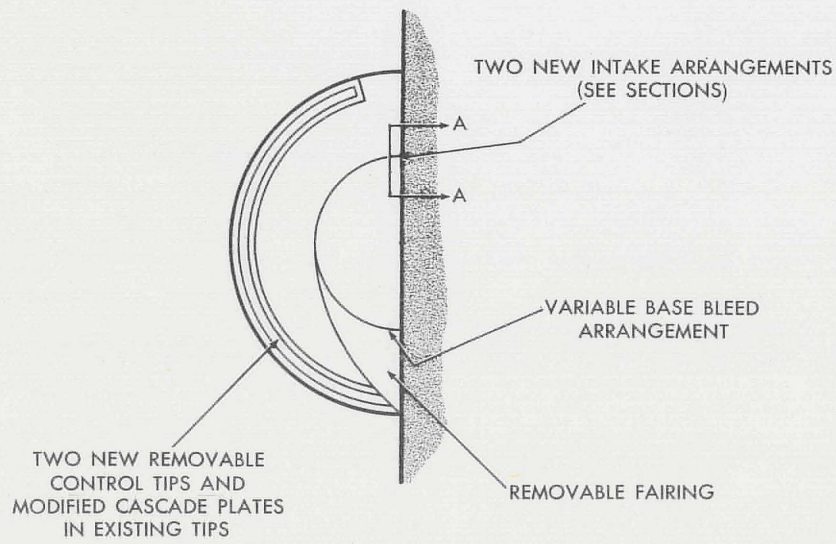
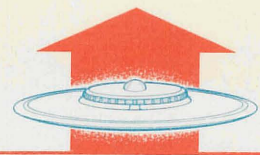

FIG. 23 PROPOSED CHANGES TO 1/23 SCALE MODEL





It is anticipated that approximately 60 hours tunnel time ($7\frac{1}{2}$ shifts) will be required for a new program on this model.

4.3 Static Tests

1.1.5.1
1.1.5.4

Certain static tests are being carried out as part of the Avro Aircraft Limited P. V. 704 program and will be reported to USAF, as follows:

4.3.1 1/3rd Scale Nozzle Development Tests

Nozzle development tests at 1/3rd scale are being carried out on the balance rig shown in the photograph Fig. 24 and the illustration Fig. 25 on the following page. The objectives are to determine the pressure losses in the outer wing combustion section and in the nozzle itself and the effective outlet area of the nozzles at various angular settings and in various positions about the wing periphery. Thrust losses are being obtained directly from this rig and converted to pressure losses for thrust estimation.

As will be seen from the illustration, the rig consists of a two component strain gauge balance, having a long flexible air supply pipe with a Venturi inside it, encastered at one end into the main air supply and supported at the other by the balance dynamometers. Cascades in the right angle elbow and a gauze downstream ensure an even flow distribution to the outer wing 1/3rd scale segment. Standard round nozzles have been used to provide a calibration for a reference pressure plane sufficiently upstream of the combustion region entry to be unaffected by flow changes in this region.

Various types of shutter in combination with flame tube proposals will be tested in this rig, until satisfactory nozzle performance is established.

It is anticipated that in due course, pressure instrumentation will be added at the nozzle exit to enable detail improvements to the nozzle flow to be carried out. If at all possible a third component may be added to the balance to enable thrust efficiency measurements to be made for any nozzle around the periphery. Results of these tests will include data on thrust efficiency, discharge coefficient and efflux angle.

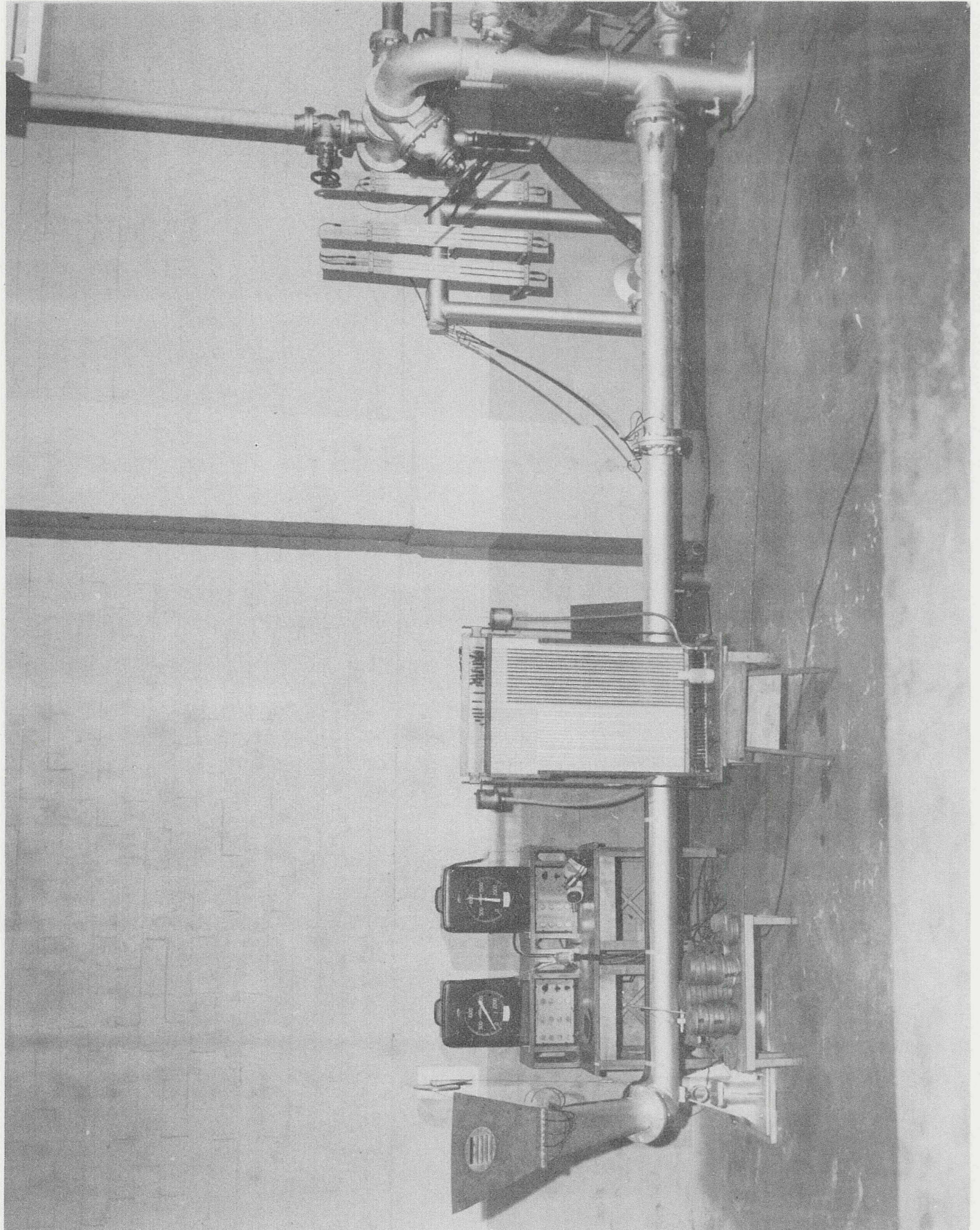

FIG. 24 1/3 SCALE NOZZLE RIG

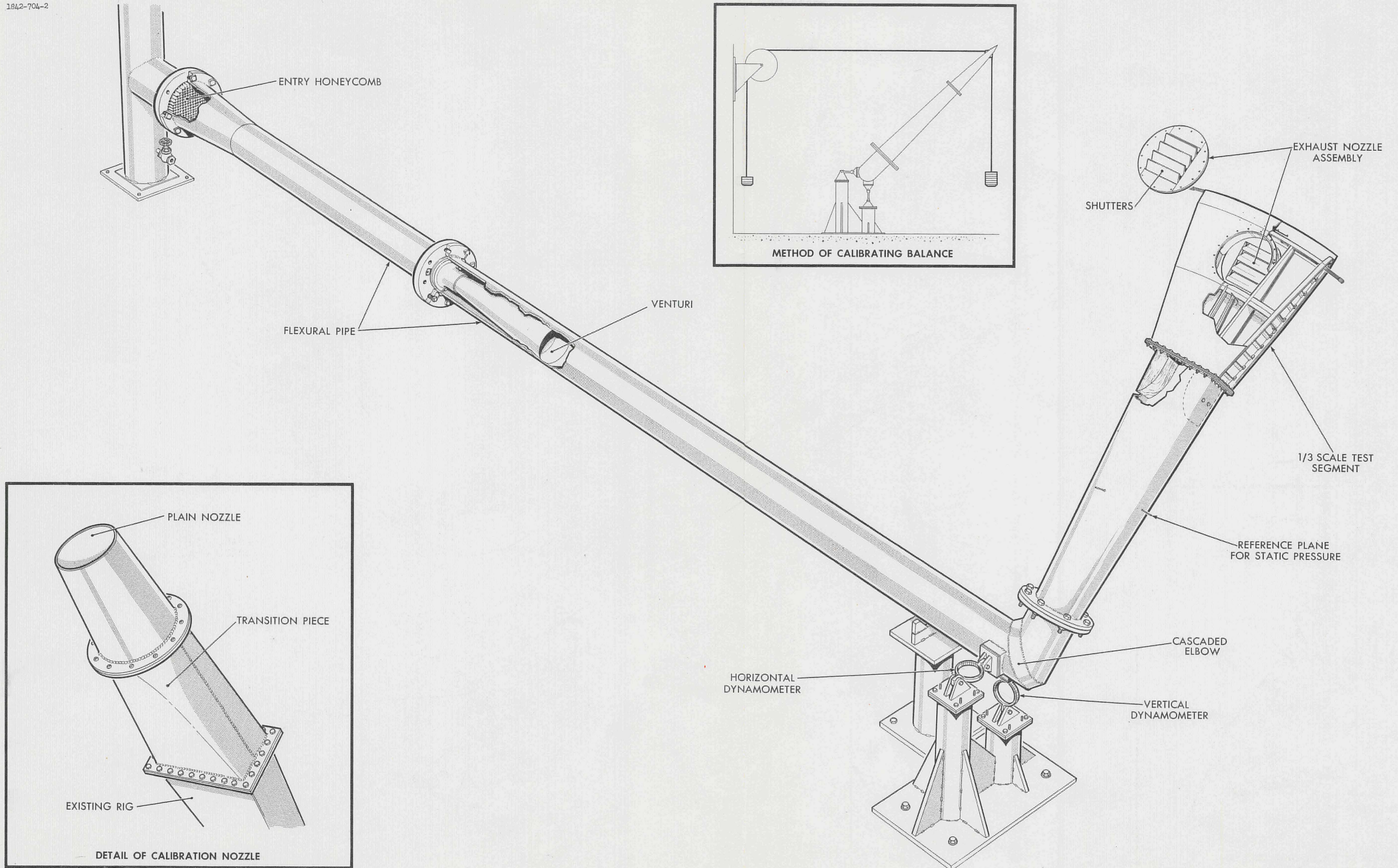
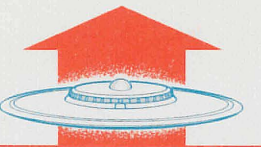
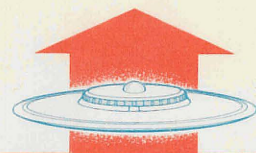

FIG. 25 1/3 SCALE OUTER WING SEGMENT TEST RIG

727-1794-1



4.3.2 1/5th Scale Air Intake Tests

It is proposed to carry out development tests of the internal flow in the air intake (between the mouth and the eye of the impeller), at 1/5th scale on a static rig as illustrated in Fig. 26. A schematic of the intended internal flow is also shown in Fig. 27.

A parallel stream of air is fed to the intake mouth by means of an entry flare and sucked through the internal passages and a transition section by means of an annular ejector (actually part of the 18" x 18" ejector wind tunnel at Avro). Alternatively, at a later stage, the entry flare will be removed and the take-off relief doors now envisaged (as shown in Fig. 27) will be fitted in the roof of the intake, to simulate the take-off case. Thus the two important cases for the internal flow in the air intake can be simulated.

The first series of tests will comprise tuft studies through the transparent intake roof, plus measurements of the yaw angle and vertical pressure profile from the elementary instrumentation illustrated. An approximate measurement of the mass flow will be obtained from a total pressure survey across the circular duct leading to the ejector and wall static pressures. Following this more complete instrumentation will be fitted and thorough total and static pressure surveys will be taken at the compressor entry station, giving the pressure loss to this point and accurate mass flow measurement.

omitted

4.3.3 Ground Effects Tests

It is proposed to continue testing on the 1/20th scale ground effect rig illustrated by photograph of Fig. 28 and the schematic perspective of Fig. 29. The balance will be improved, the undersurface configuration brought up to date, and the internal arrangements changed to ensure a completely even distribution of the flow from the peripheral jets.

It is also proposed to determine, by mounting the ground on a three component balance, whether the moments on the ground reflect those on the model, in which case a hovering mechanical analogue is visualized as discussed under stability and control in Section 6.

4.4 Work Chart Scheduling and Cost

Fig. 30 is a work chart illustrating the interdependence of

the items under this head, Fig. 31 shows a proposed schedule. Cost and manhours estimates are shown on pages 95 - 108. Wind tunnel occupancy time is assumed at no cost to the contractor. The schedule is of course tentative since it depends on the availability of tunnel time.

2054-1794-1

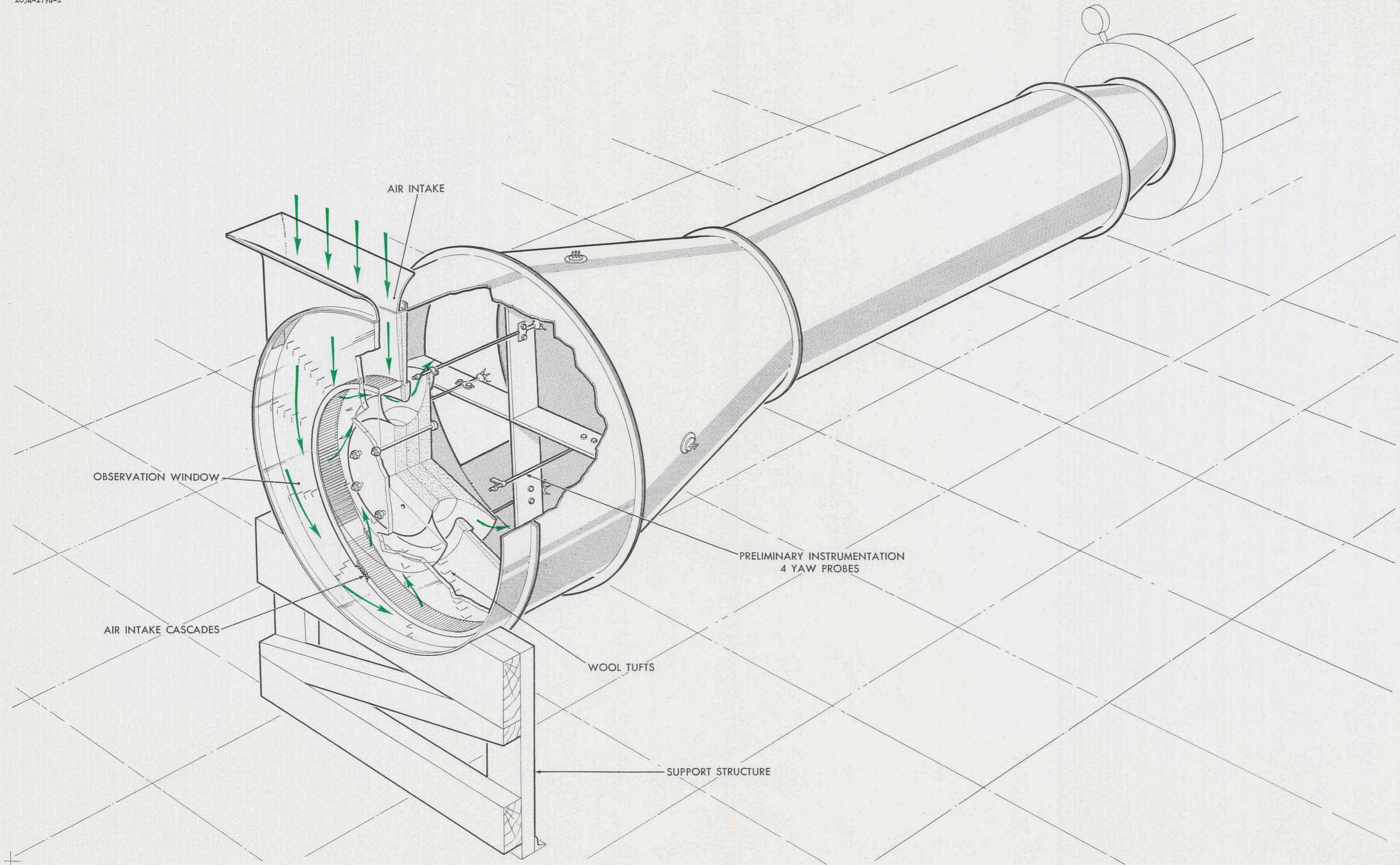
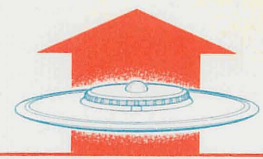

FIG. 26 1/5th SCALE AIR INTAKE MODEL

SECRET

727-1794-1



2049-1794-2

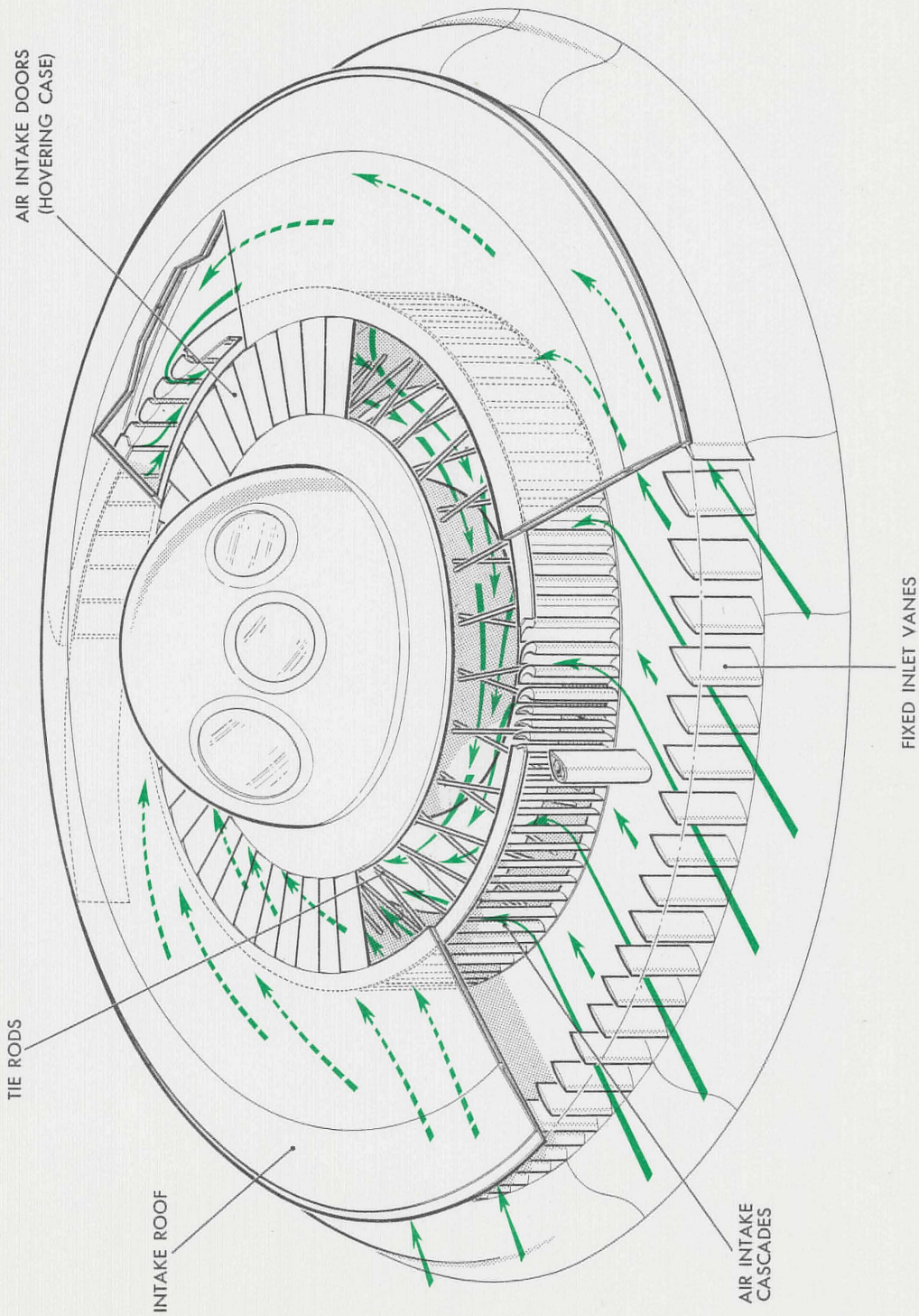

FIG. 27 INTAKE ARRANGEMENT

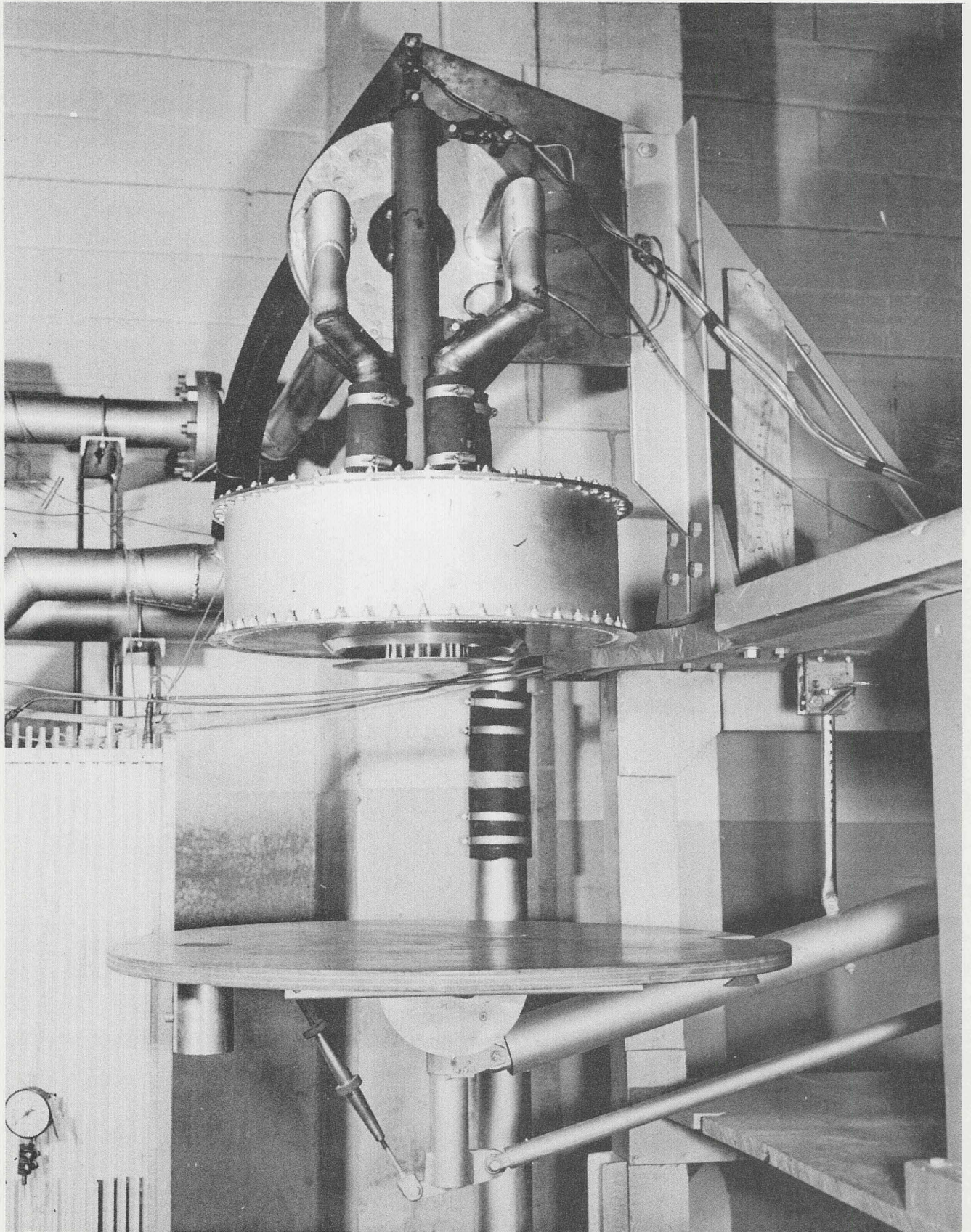
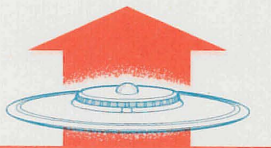

FIG. 28 GROUND EFFECTS RIG



PROJECT 1794

RIG DRWG. NO. SK 21295 SHT. 1
 MODEL DRWG. NO. 17 SK 30226
 27 SK 30038
 20" DIA. MODEL

1664-1794-2

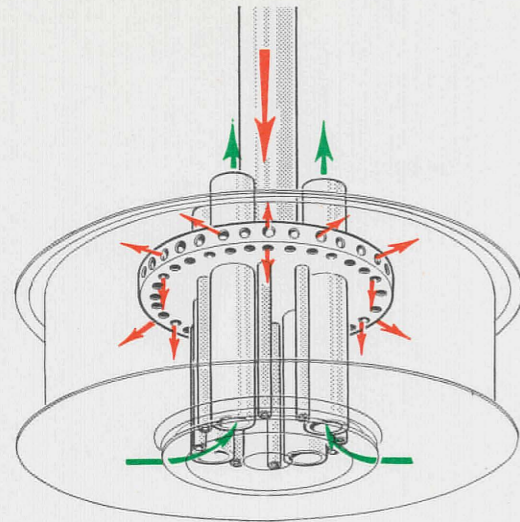

DETAIL OF MODEL NO. 1/9/133358514

NOTE:

1. THIS IS SHEET NO. 5 FOR OTHER ILLUSTRATIONS REFER TO SHEETS NO. 1, 2, 3, ETC. FOR OTHER CONFIGURATIONS REFER TO TABLE
2. FOR PYLON PITOT REFERENCE PROBE AND TAP, AND ALSO THE ARTIFICIAL GROUND REFER TO ILLUSTRATION OF RIG

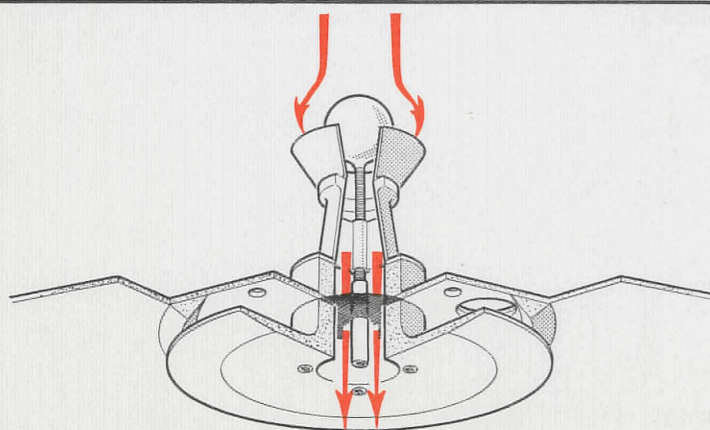

DETAIL OF MODEL NO. 1/9/132357514

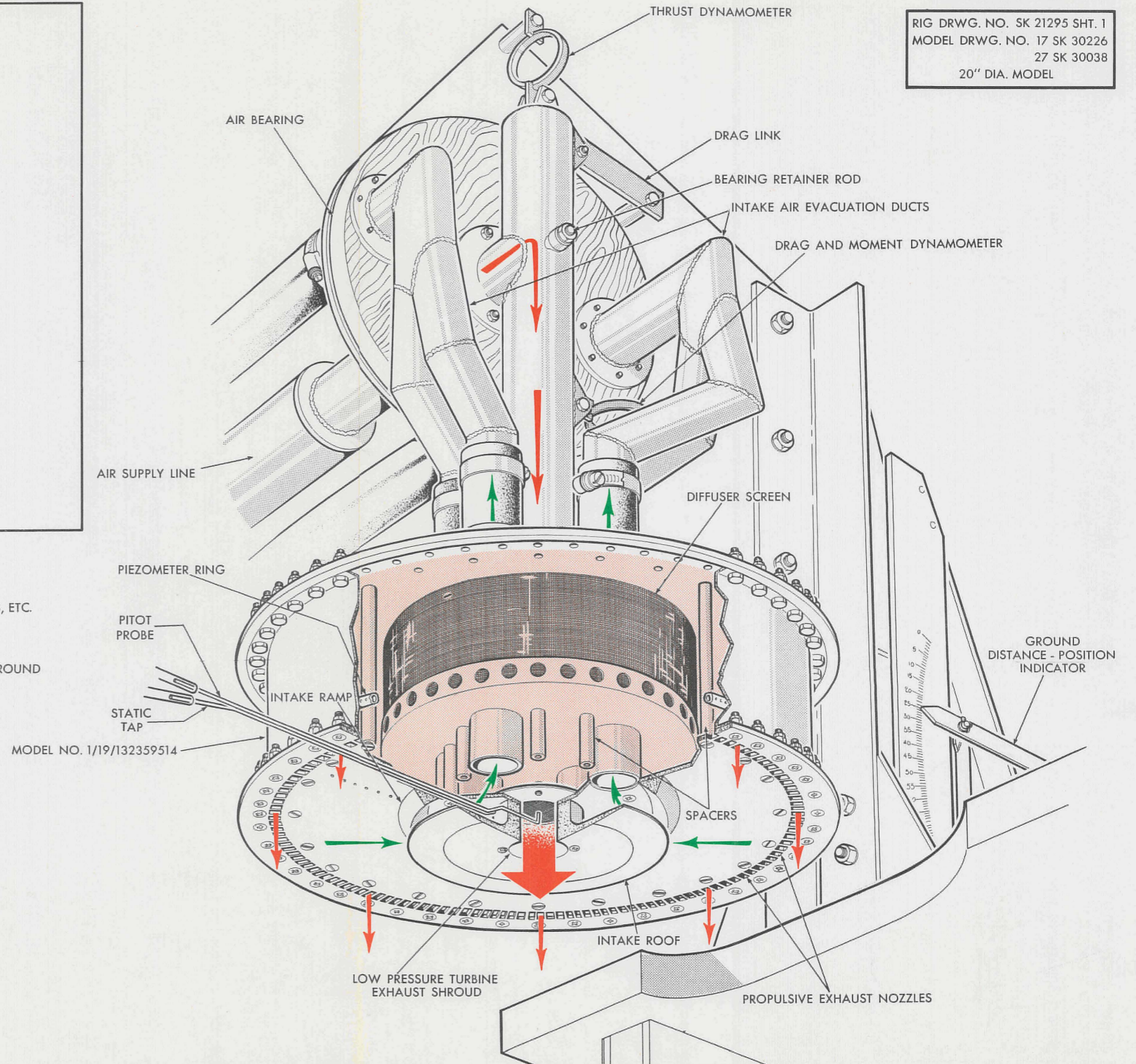
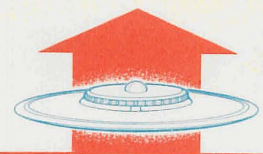

FIG. 29 GROUND EFFECTS RIG

727-1794-1



2116-1794-2

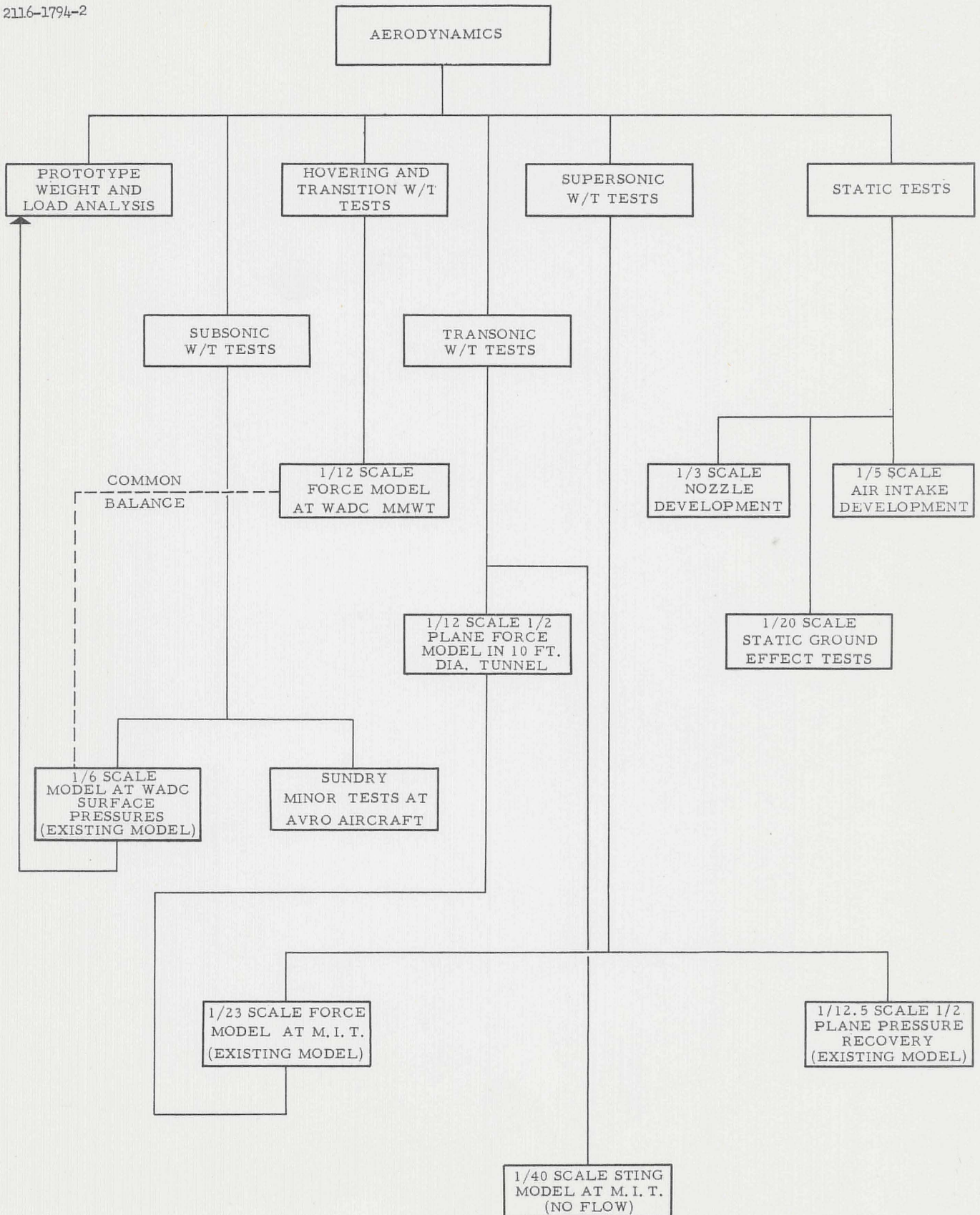

FIG. 30 WORK CHART - AERODYNAMICS

5. PROPULSION

Present policy is to carry out development of the propulsion system on a complete engine, comprising the six Viper gas generators and the main eight foot diameter radial flow turbine compressor pair, but without the afterburners and nozzles fitted. This six Viper rig involves the building of the basic structure of the aircraft, comprising the fuel tanks and mid-wing section, together with special outlet nozzles of different sizes to control the running of the large radial flow fan. The design for this piece is complete, and the design point has been chosen at the sea level static case with consideration for the fact that air entering the lower intake may be heated to some degree by the exhaust flow from the gas generators. Construction is already well advanced and it is expected to be ready for first running at about the end of July 1957.

This unit, which embodies the design of the major portion of the P.V.704 research aircraft, is part of the P.V.704 program but the results of all tests will be made available to USAF, the additional reports required etc. being regarded as part of the USAF program. Considering the work proposed under the heading of propulsion in detail, it may be itemized as follows.

5.1 Analysis

5.1.1 Design Point

1.1.6

As noted above, a preliminary design point study, upon which the gas dynamic design of the first set of rotor blades has been based, has already been completed. With standard day air entry conditions the compressor is expected to operate with good efficiency considerably below the surge point and thus a design point has been chosen to allow for the air entering the lower intake being heated to some degree by the gas generator exhaust (it will be remembered that the Viper engines breathe entirely from the upper air intake); it is estimated that the compressor will not surge until the intake temperature reaches approximately 600°K; and since from tests it is not expected that the lower intake temperature will exceed 400°K as a result of the gas generator exhaust, it is anticipated that some degree of afterburning

will be possible in the take-off case. Analysis at the design point is continuing, with estimates of possible modes of operation and further analysis will be required as soon as test results become available. From the gas dynamic point of view the most likely cause of difficulty appears to be that of matching the main power turbine to the Viper engines; however, the blades have been designed so that they can be replaced in convenient sub-assemblies, so that re-blading the turbine or compressor is not expected to cause undue delay.

5.1.2 Off-Design Characteristics

Estimates of the thrust of the propulsion system based on manufacturers' engine data, and estimated compressor and turbine characteristics, duct and combustion losses etc., will first be made in order to determine the performance potential of the research aircraft; and refined as improved data becomes available, largely from the six Viper rig, but also from aerodynamic nozzle and combustor test and from the Viper engine manufacturers.

5.1.3 Control System

Studies of the thrust and specific fuel consumption of the propulsion system with alternative controlled modes of operation will be analysed in conjunction with behaviour determined from the six Viper Rig. A schematic drawing illustrating a tentative system is given in Fig. 34: when a satisfactory system giving the required operation has been designed, and tested as far as possible on the six Viper rig, the propulsion unit performance for the whole range of altitude and forward speed will be presented in non-dimensional form.

5.1.4 Transient Response

The transient response of the engine to throttle setting will be determined from measurements on the six Viper rig and, if unsatisfactory, analyses will be made in order to enable the characteristics to be improved.

5.2 Test and Development

5.2.1 Single Viper Air Intake and Exhaust Tests

The double cascaded bend to the intake of the Viper gas

1.1.5.2
1.1.5.3
1.1.5.5
1.1.5.6
1.1.5.7
1.1.5.8

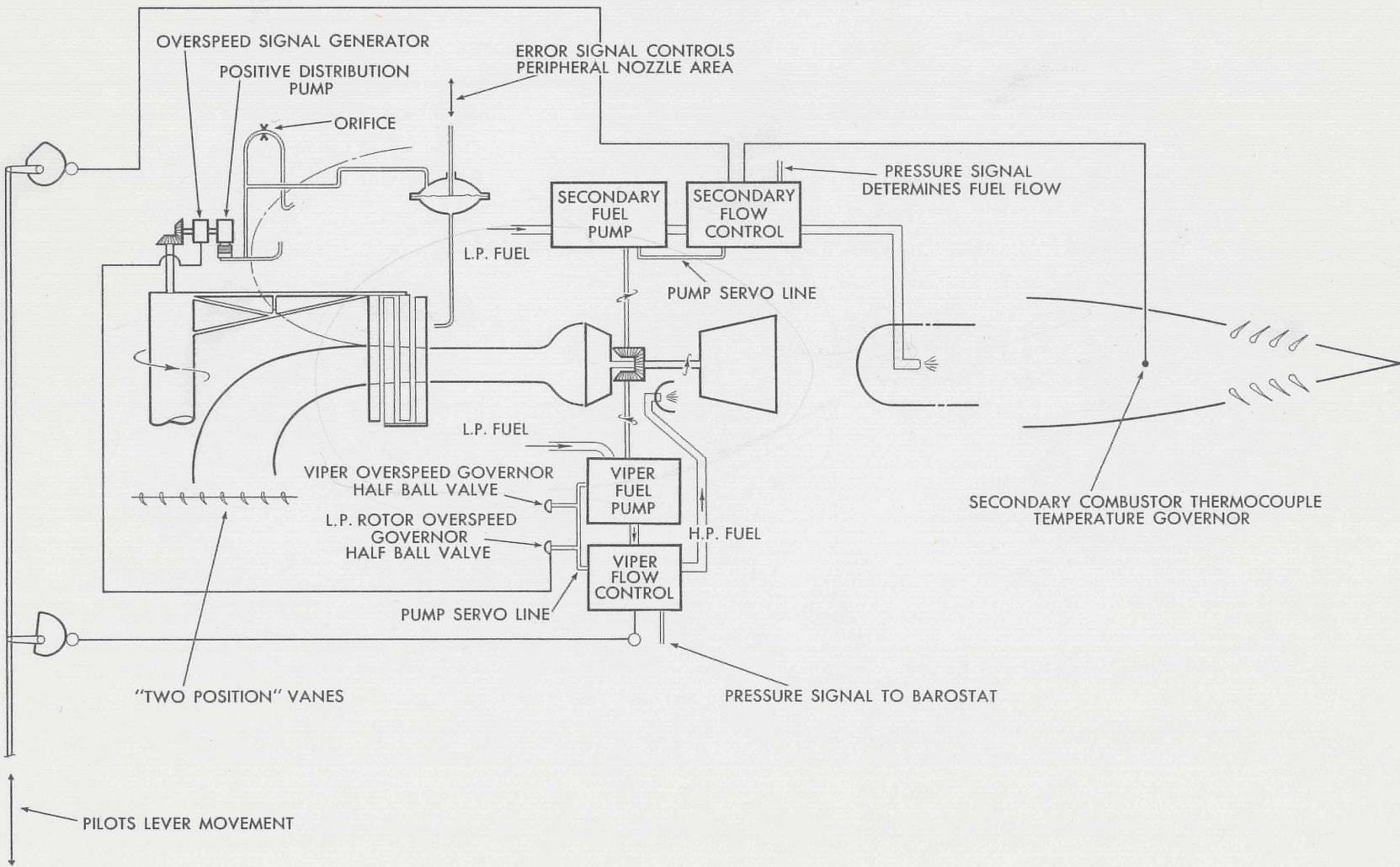
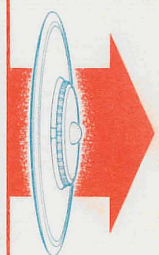

FIG. 34 SCHEMATIC OF PROPUSION CONTROL SYSTEM

SECRET



generator and the exhaust fan-tail with nozzle guide vane to the main turbine have already been tested as part of the P.V.704 program on the rig shown in the photographs of Figs. 35, 36 and the illustration of Fig. 37. For the intake, no detail measurements of the flow were taken; the engine ran perfectly satisfactorily, and it appeared that no loss of thrust could be determined. The exhaust fan-tail was tested several times and attempts were made to improve the flow at the sides. Measurements of the velocity distribution reflected a very poor distribution of velocity immediately behind the turbine on the particular engine used for test and the actual velocity distribution at nozzle exit is also difficult to determine since it was only possible to test at atmospheric exhaust pressures.

Development tests on the exhaust diffuser are anticipated with probable change in design to, if possible, sweep the exhaust in one direction and so avoid the diffusion and re-acceleration necessary with the present design.

5.2.2 Balance and Over-speed Rig

It is proposed to balance the main rotors and if possible test to limit load in the rig shown in the photograph of Fig. 38 and the illustration of Fig. 39. As will be seen from the illustration this rig is mounted immediately behind the existing test house so that the Viper engine on its present stand can be used to drive the turbine: the compressor rotates in a hollow box which also forms a shield, as shown, and by this means it is hoped to destroy most of its pumping capacity so that the rotor can be spun up by the very inefficient drive of the Viper engine jumping across two rows of turbine blades similarly set. If necessary, stators can be interposed between the first and third turbine stages: however, approximate calculations indicate that only about 70 horsepower should be required to drive the wheel at design speed.

Both wheels can be tested successively in this rig; instrumentation will consist of an I.R.D. vibration analyser, cameras to observe the deflection of the rings (see Fig. 3) and yaw probes to determine the outlet angle from the first turbine stages.

5.2.3 Six Viper Test and Qualification Rig

The rig is illustrated by the drawing of Fig. 40 and as

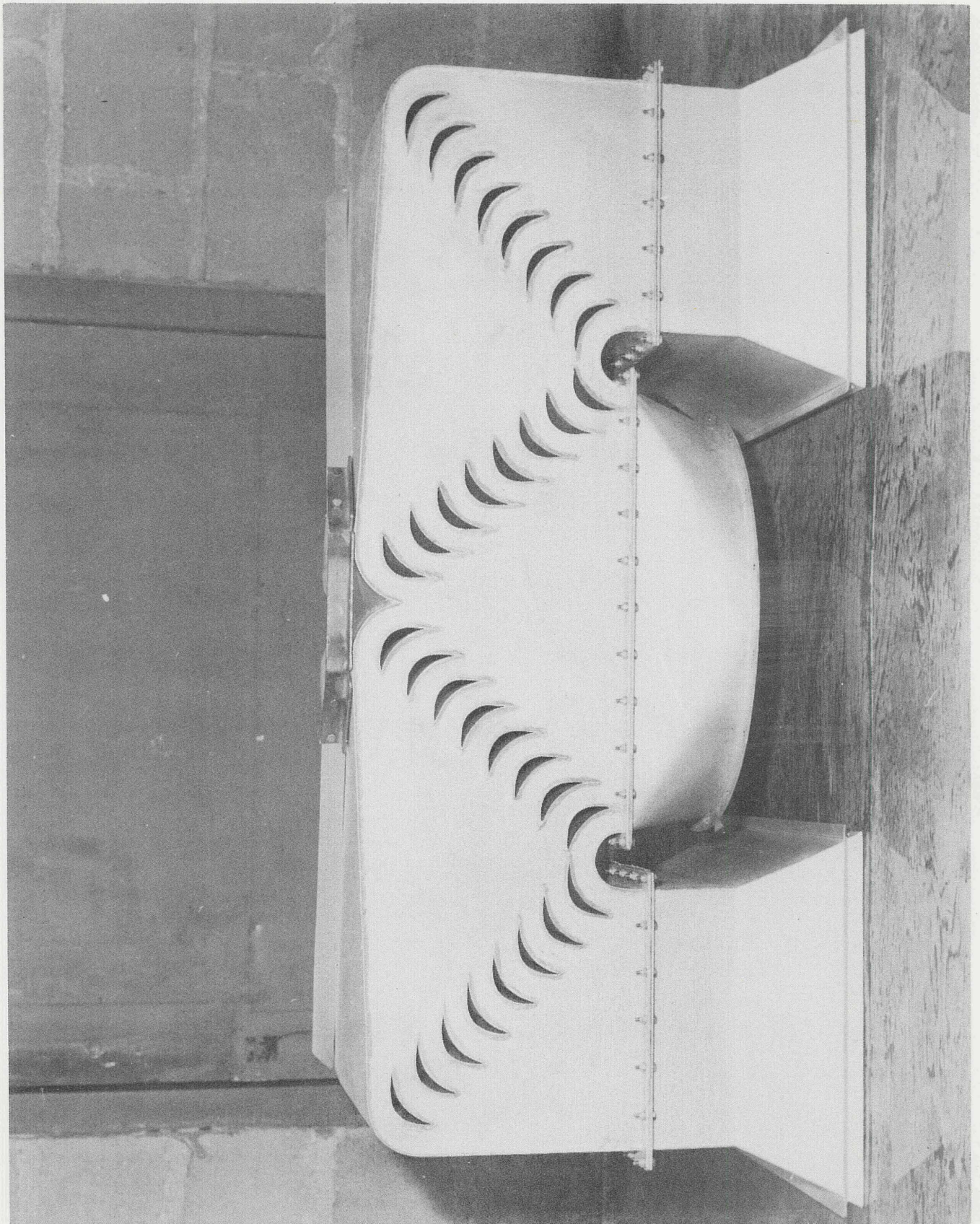

FIG. 35 VIPER AIR INTAKE

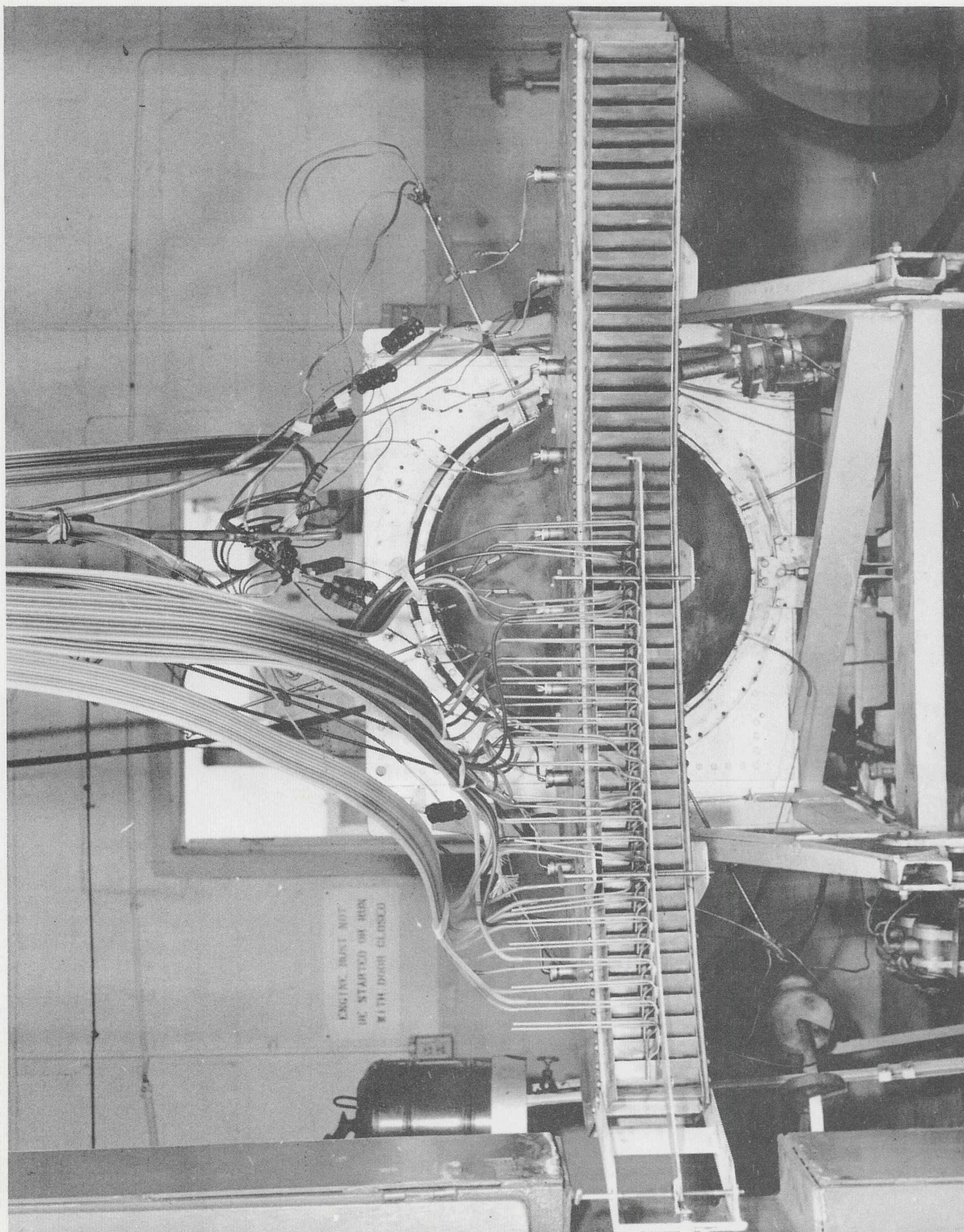
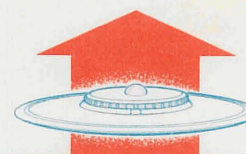

FIG. 36 EXHAUST FANTAIL TEST

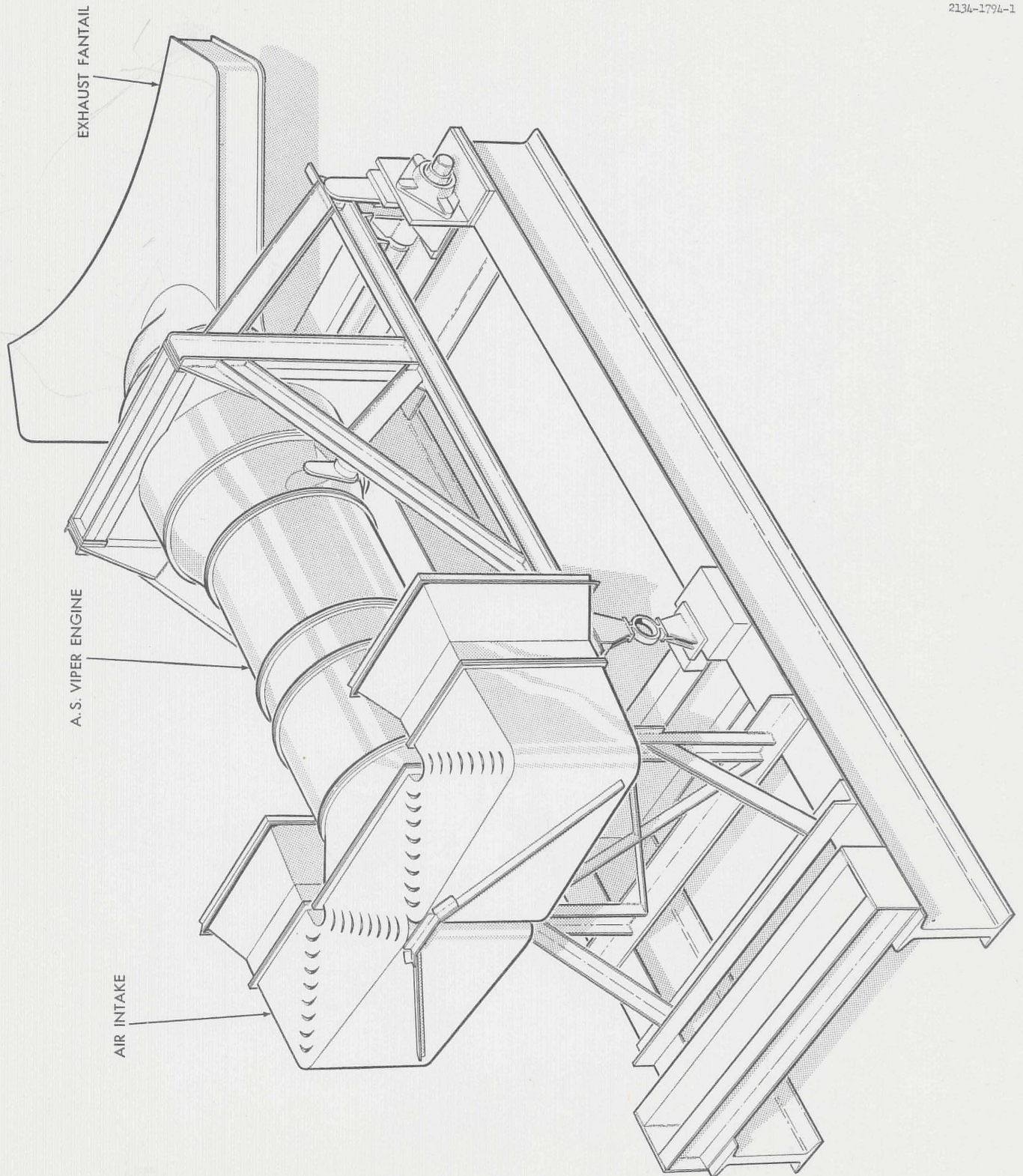
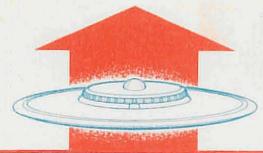

FIG.37 VIPER AIR INTAKE AND EXHAUST FANTAIL

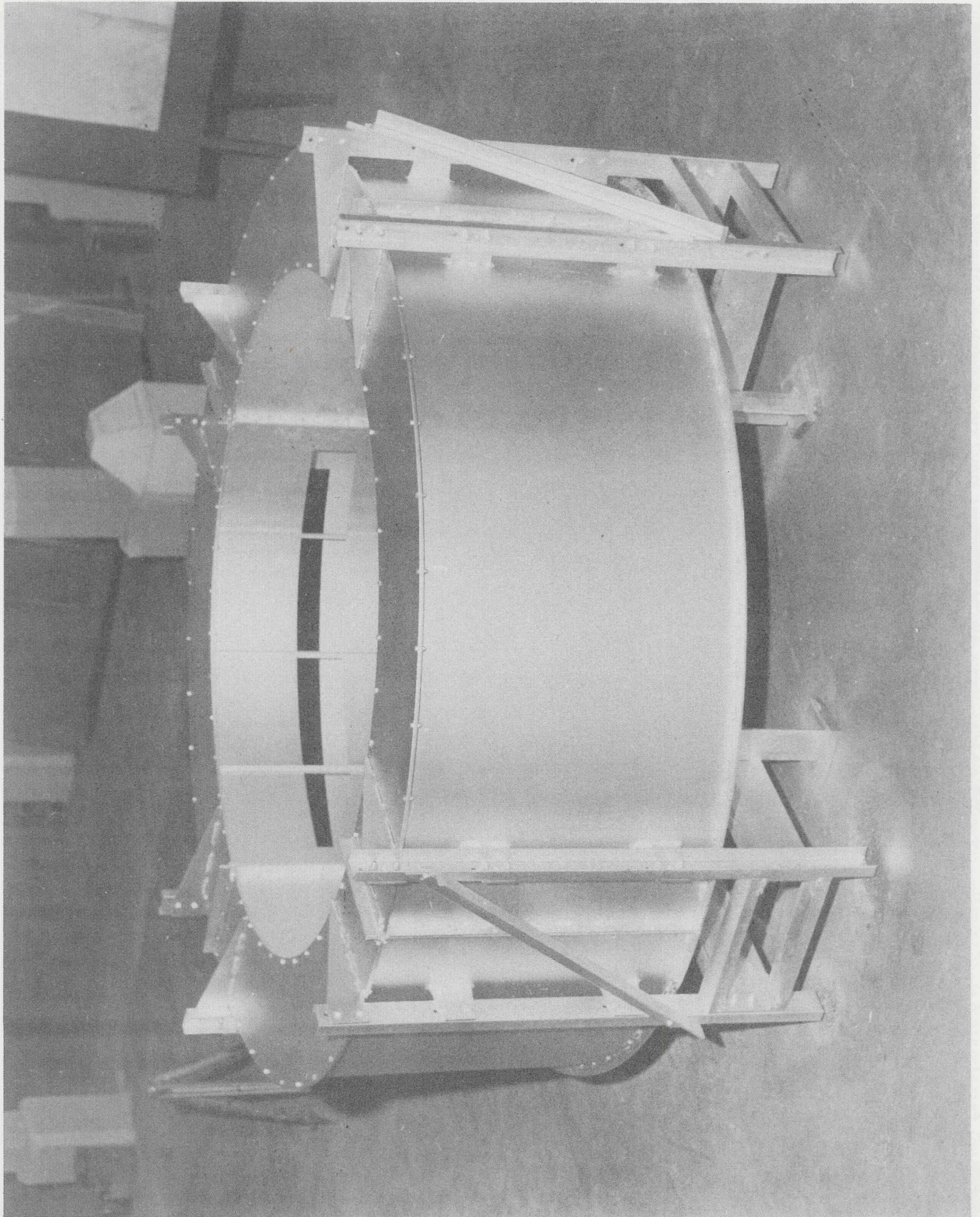
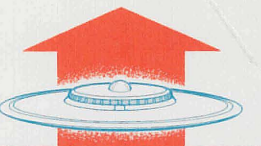

FIG. 38 OVERSPEED RIG



2055-1794-1

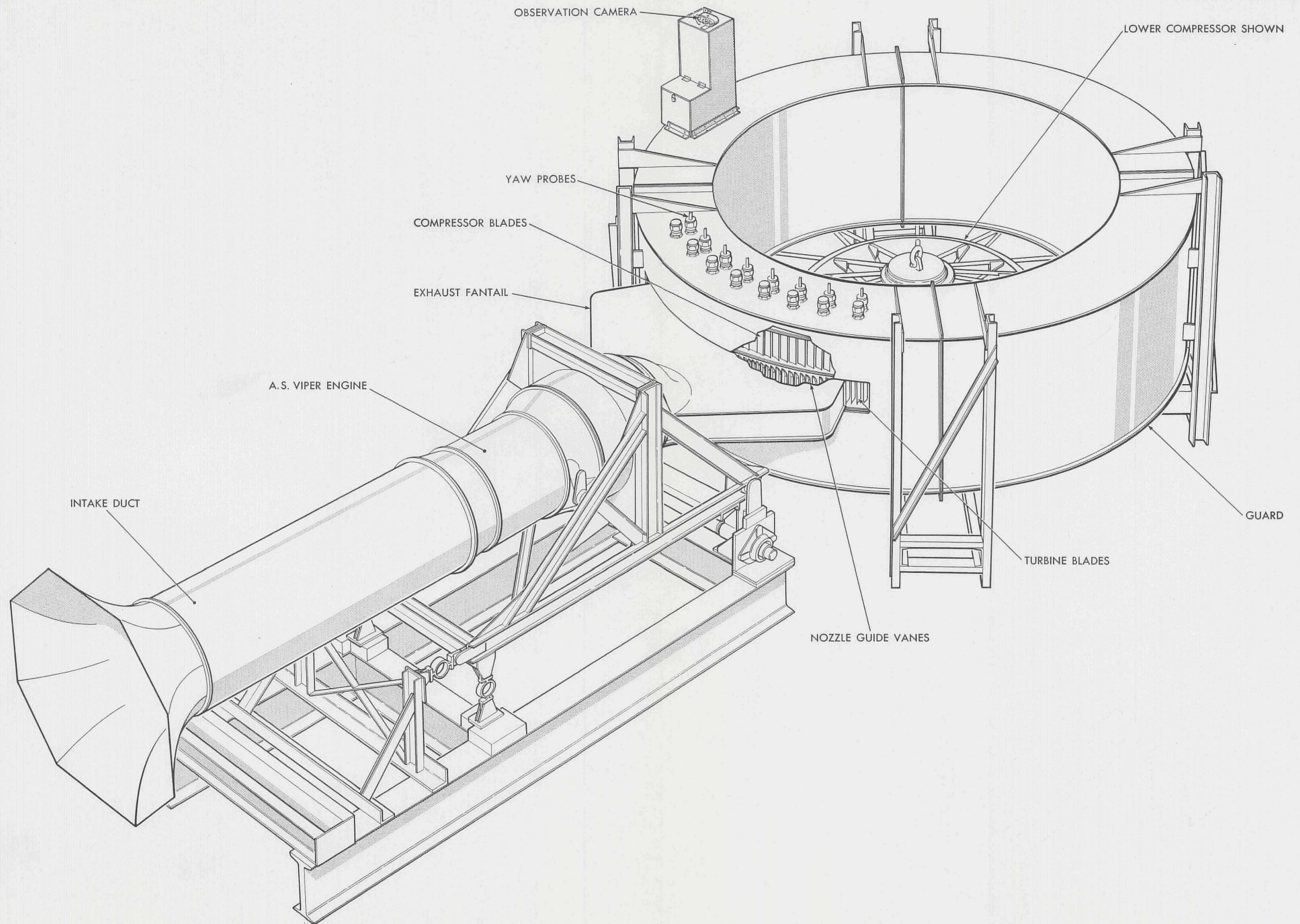

FIG. 39 BALANCE AND OVERSPEED RIG

SECRET

727-1794-1



1867-704-2

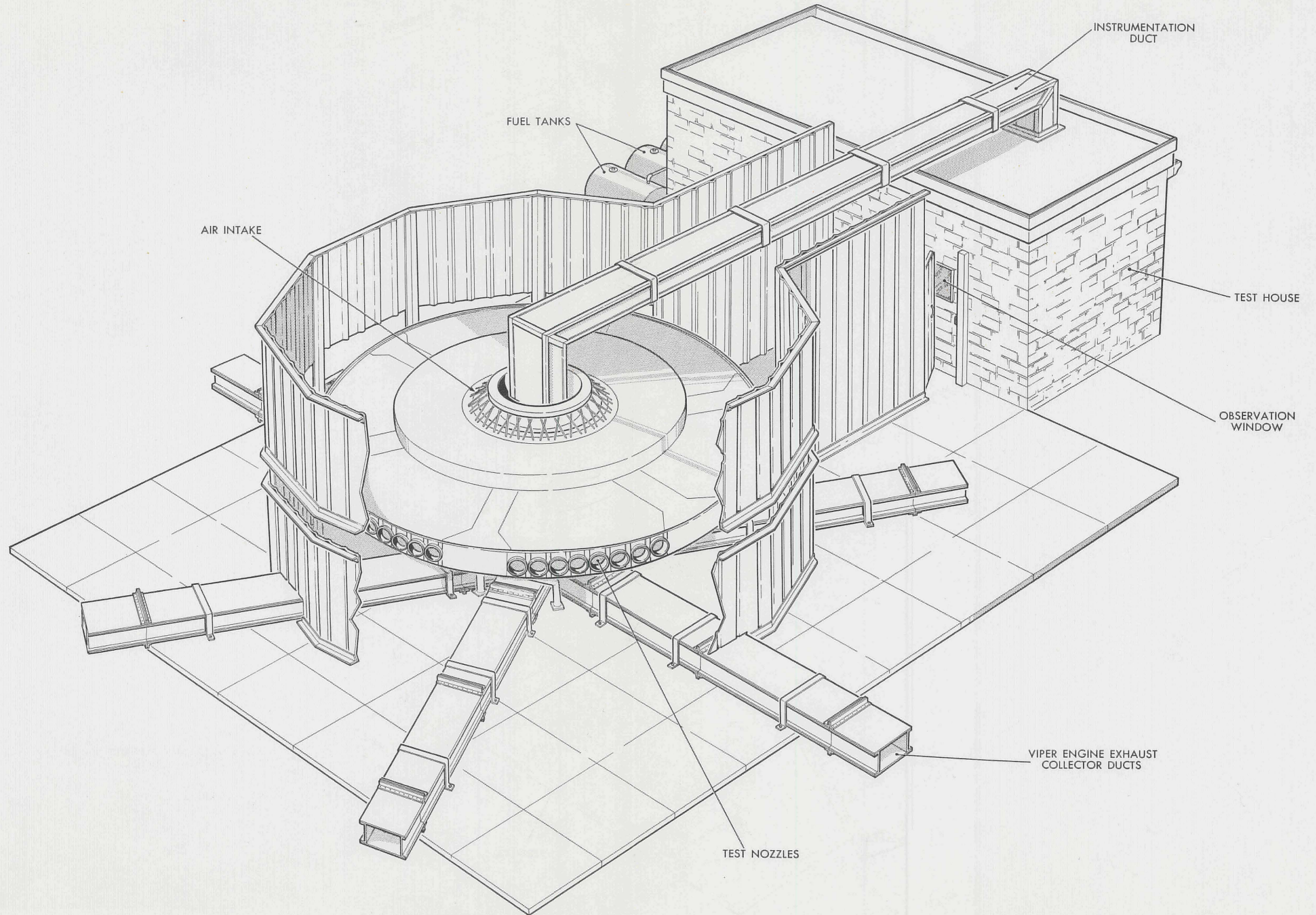

FIG.40 TEST HOUSE AND SIX VIPER TEST RIG

explained above consists of the whole basic structure and propulsion unit of the research aircraft. Initially ducts are fitted underneath the rig to carry away the exhaust from the Viper gas generators and also most of the air intake structure will be omitted, leading the annular air intake sinks open as far as possible to atmospheric pressure. Instrumentation will be carried back to the test house through an overhead duct (shared by the rig and engine controls) and consists of pressure and temperature measurements and rpm. Pressure surveys will be taken at radial positions at the following stations.

1. Air entry.
2. Immediately in front of the compressor.
3. Immediately behind the compressor.
4. In front and behind the turbine.

In addition a complete pressure survey will be taken at the exit of each outlet duct from one 1/6th segment of the periphery and also underneath the aircraft beneath the Viper exhaust, for thrust determination. Provision will be made for the installation of slip rings on the rotor (since the rpm is so low, large diameter slip rings should work quite satisfactorily) but the compressor and turbine blades will not initially be strain gauged.

Fuel will be supplied to the rig from separate fuel tanks installed behind the test house and engine starting will be by compressed air from an outside source.

From this rig the overall efficiency of the propulsion system can be determined including the components of compressor efficiency, turbine efficiency and the several duct losses. As development proceeds the air intake structure will be fitted and the ducting carrying away the exhaust gases will be eliminated and means provided to control the temperature of the air entering the lower intake up to the maximum value expected for the aircraft when hovering in the ground cushion.

The support afforded by the supply of additional engines as suggested by the USAF will provide satisfactory contingency allowance for engine failure in the test rig. Specific detail of the proposal for spare Viper engine supply is given in Section 5.3.

It is anticipated that a qualifying test according to specification MIL-E-5156B for prototype experimental flight will be

undertaken on the first six Viper test rig and allowance has been made for this to be carried out.

5.2.4 Combustion and Fuel System Development

1.1.7

5.2.4.1 Combustion Development

It is anticipated that Combustion Development will be sub-contracted to specialists in this field. It is expected that the principal phase of combustor development will be carried out on a single can segment of the outer wing combustion system, after preliminary flow visualization tests using water have been conducted. The sample combustor segment will then be fitted into an appropriate facility and tested over a full range of entry conditions up to Mach 3.0 as defined in Figs. 41 and 42. The combustion problem is more completely described by the graph of estimated combustion efficiency and extinction limits given in Fig. 43, and the diagram of operating conditions shown on page 66.

changed

The first phase of combustor development testing, is covered by the work proposed and will enable a similar graph to that of Fig. 43 to be constructed and the pressure loss at the various operating conditions in the table to be determined for the first working combustor. This development phase is covered by the present contract.

These results will then be applied to determine the performance of the proposed Mach 3.0 research vehicle and both the necessary degree of improvement and the required continuing level of effort may then be determined.

It is further anticipated that sufficient mechanical development will have been carried out during this phase to enable the one set of combustion equipment for the prototype P.V.704 to be manufactured.

5.2.4.2 Fuel System

Fuel System development will be sub-contracted to specialists along with combustion development. System requirements for a Mach 3.0 aircraft of the 1794 type will be analyzed.

It is anticipated that the fuel system for this vehicle will

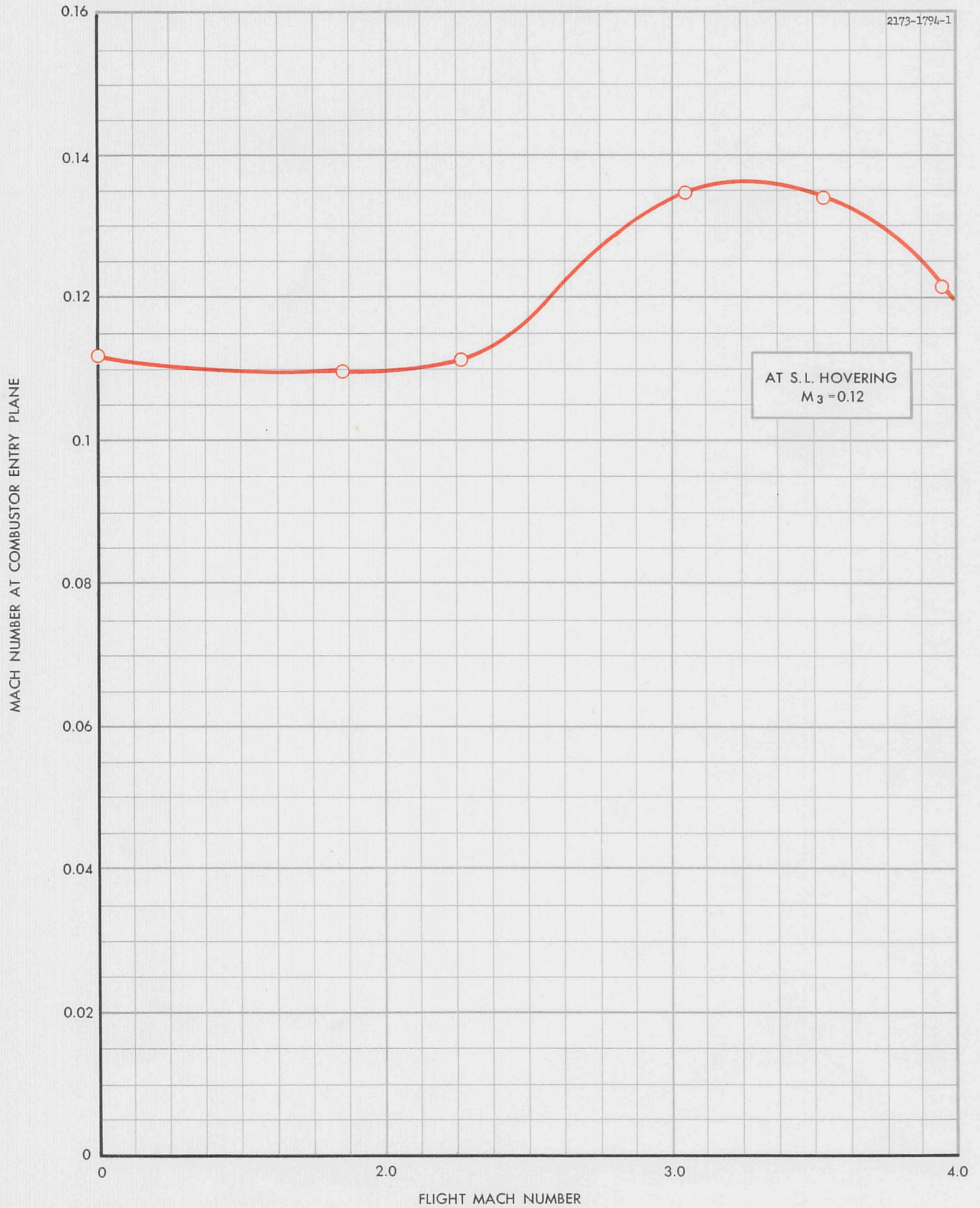
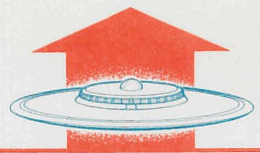

FIG.41 COMBUSTION ENTRY MACH NUMBER

726-1794-1

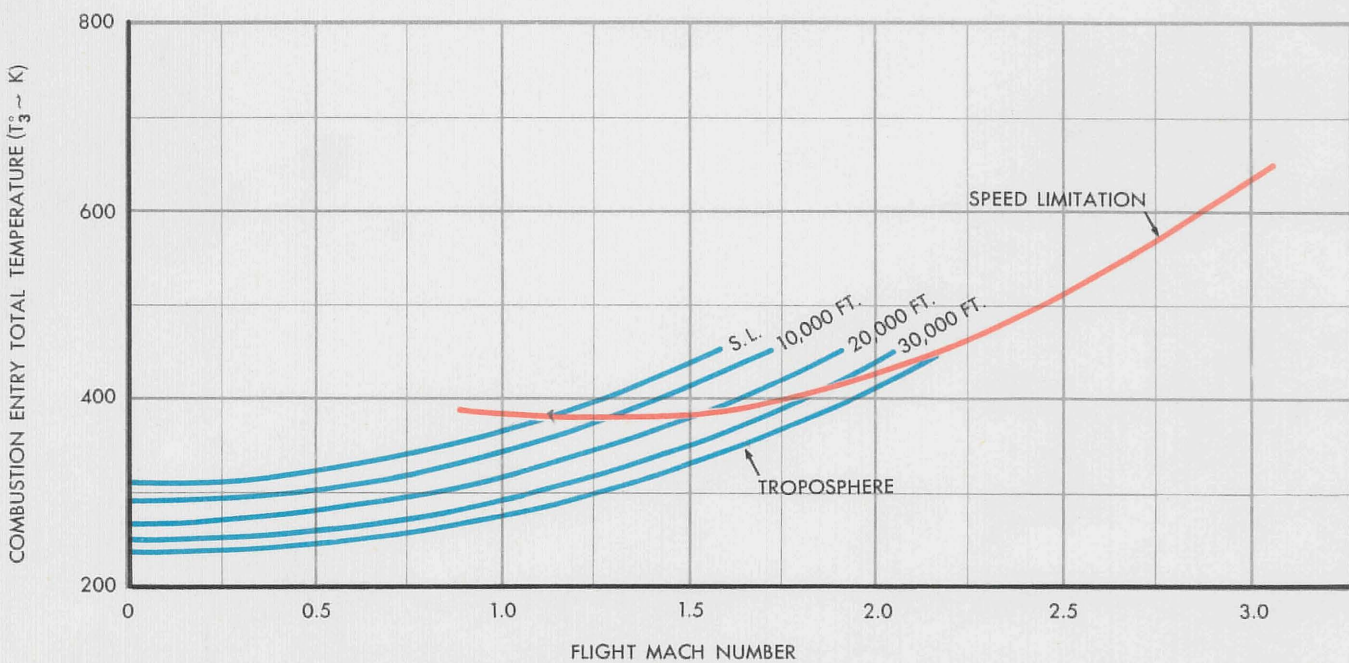
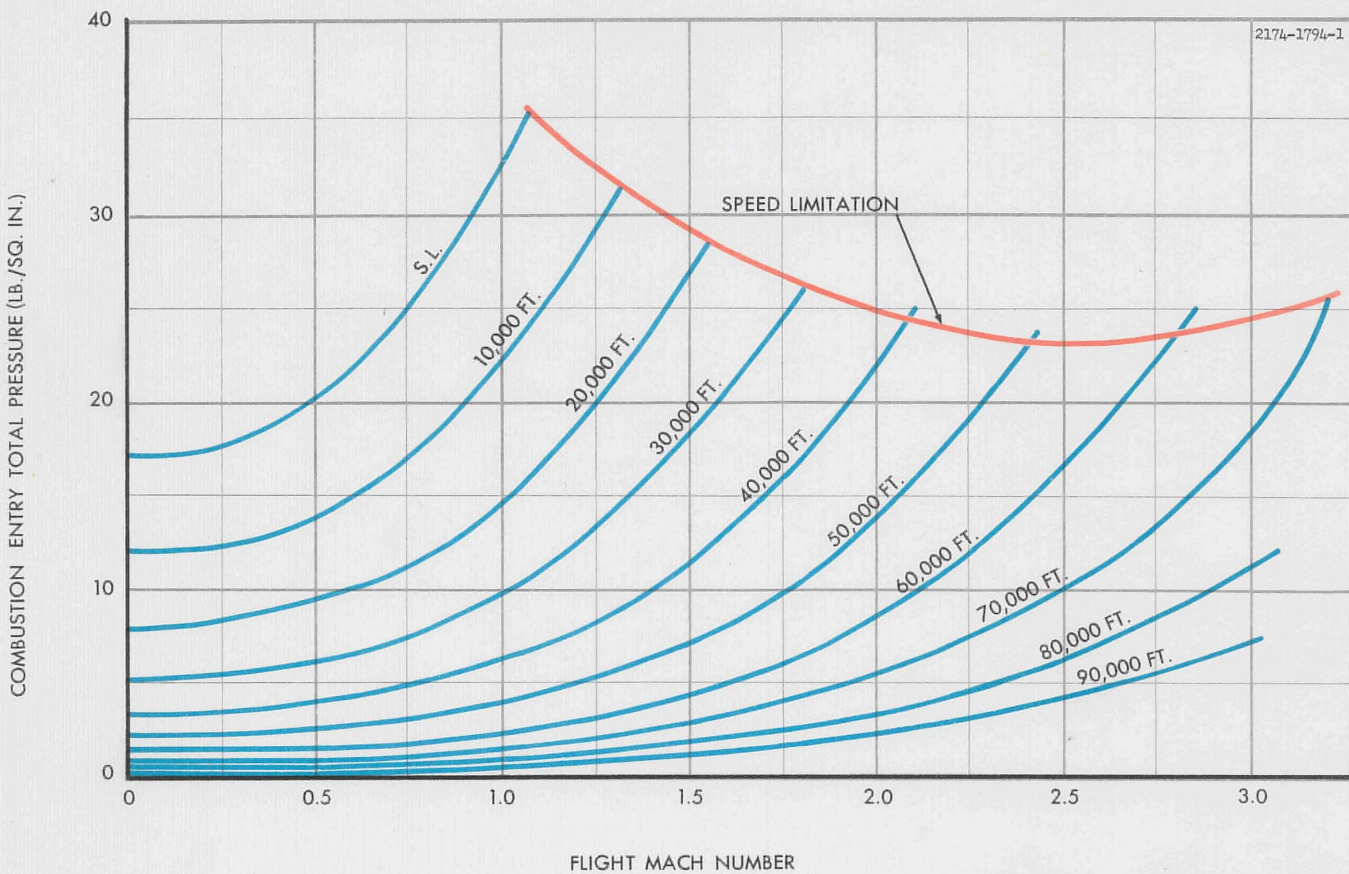
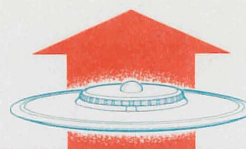

FIG.42 COMBUSTION ENTRY PRESSURE AND TEMPERATURE

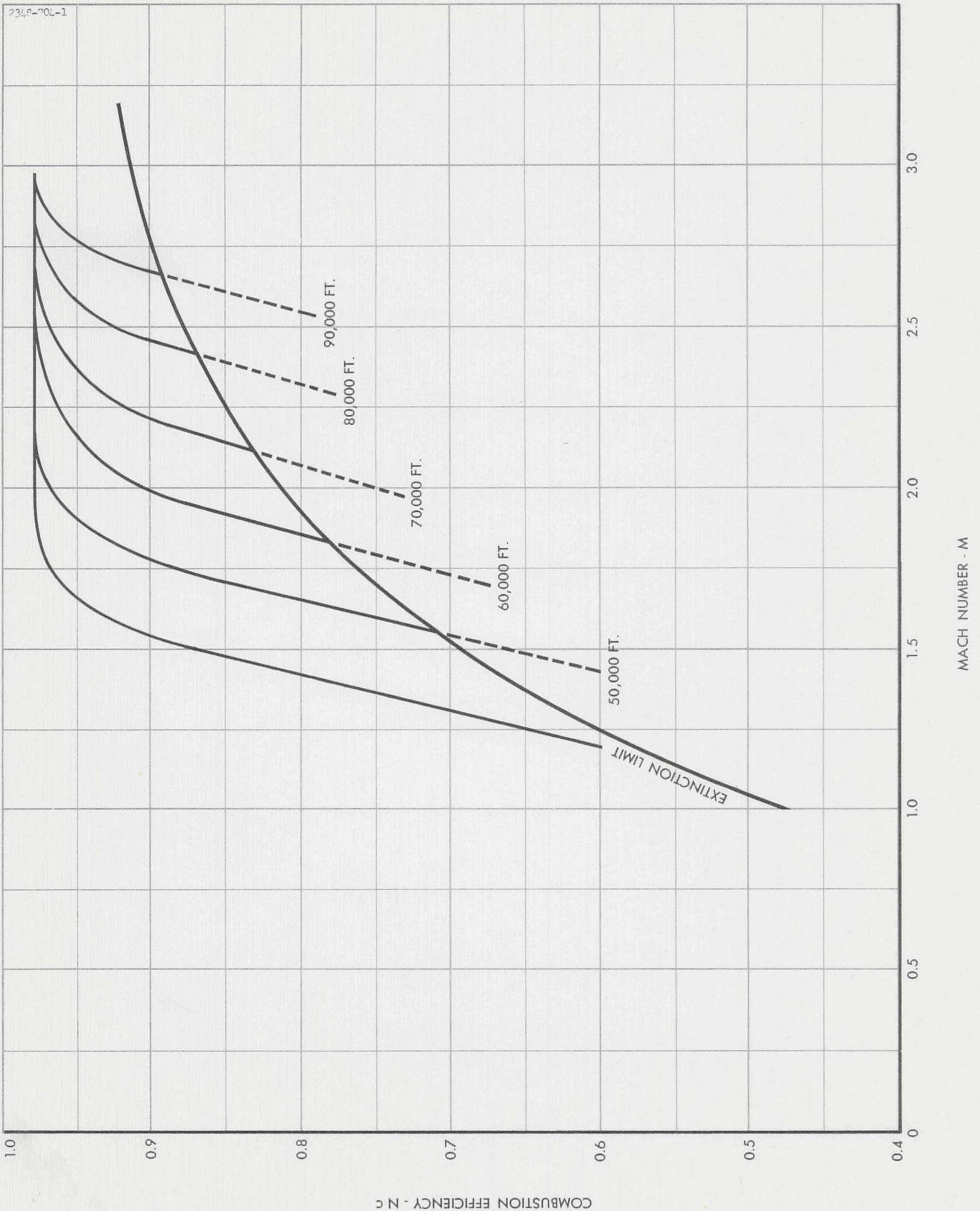
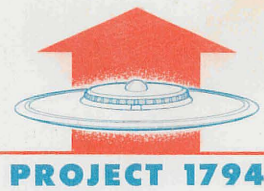

FIG. 43 COMBUSTION EFFICIENCY N_c VS MACH NUMBER - M



involve the design and development of new items such as the flow control unit etc. Standard fuel pumps will however be suitable, and it is probable that one pump in each sector will supply fuel both to the associated engine and the outer wing combustors. This will probably be a variable displacement piston type pump fitted to the new accessories gear box of the Viper engine which is shown in Fig. 4.

With regard to control, a constant maximum combustion temperature can be approximately maintained by the use of a fuel air ratio control giving a linear relationship of fuel flow to air pressure. However at high aircraft flight Mach numbers the line departs appreciably from a unique characteristic due to the rapid increase of air temperature at inlet to the combustion system. Two methods are available to reduce or eliminate this discrepancy. The first is to sense the variable temperature and apply this as a correction to the fuel air ratio control. Alternatively a good degree of compromise can be achieved by relating fuel flow to the total ram pressure sensed from a simple pitot head measuring the pressure after a simple plane shock. The latter method gives a reasonably constant combustion temperature for a given throttle setting and is probably satisfactory.

In order to control maximum temperature, a temperature limiter will be included. This will probably take the form of a mercury vapor pressure unit inserted in the combustion system prior to the nozzles which reacts on a fuel potentiometer controlling the fuel flow going to combustion. In addition to controlling maximum temperature some arrangement will be required to prevent the Viper engines from overspeeding the main central rotors. This can be achieved by the use of a governor controlling the fuel to the Viper engine. A preliminary diagram of the whole control system is given in Fig. 34.

For the Mach 3.0 research aircraft all control units will, of course, be designed from material suitable for the temperature likely to be attained during high speed flight. Up to Mach 3.0 this is not expected to present any very serious problems.

The foregoing remarks approximately describe the type of system which is envisaged and upon which a thorough analysis and design study will be submitted. For the prototype aircraft, however, a much simpler fuel system is initially proposed. This will be installed in the aircraft from

the very start, and will assist with the hovering control and will provide an early practical introduction to the effects of combustion in the outer wing. This system will not require the development of fuel system units since it will be made up of standard existing items. The fuel pumps will be those already on the Viper which have a capacity double that required to supply the Vipers. The flow control unit will be a simple proportional control valve enabling the aircraft to operate up to some limited altitude of the order of 10,000 feet.

5.2.4.3 General

To recapitulate briefly the scope of work included in this phase of combustion and fuel system development is:

- (a) First phase development of sample combustor, to enable one aircraft set to be manufactured and including evaluation of performance for application to Mach 3.0 aircraft study. *new*
- (b) Manufacture first of a 1/6 segment set followed by a complete aircraft set of the above combustors - i. e. the flame tubes, burners etc., not the outer wing into which they will be fitted; the latter will be done by Avro Aircraft as part of the P. V. 704 program.
- (c) Design and analyse a fuel system for a Mach 3.0 aircraft and associated control system.
- (d) Design and manufacture a basic fuel system using existing components and the Viper engine fuel pumps.

A preliminary design specification based on estimated values will be submitted prior to initiation of development effort.

Further to this, i. e. after completion of this phase of work, a general design specification for the combustion and fuel system will be written. This will form a separate part of the propulsion system report supplementary to the specification of the propulsion system as a whole and MIL-E-8220 (ASG) will be used as a guide in its preparation. The following specific items will be included.

- (a) Design information necessary to define the components, assemblies and systems to be developed, including drawings, weight estimates and material requirements.
- (b) Variations of inlet conditions (temperature pressure and Mach No. profiles) appearing at the burner face during the more significant phases of engine operation. (Note - Preliminary values are quoted in Figs. 42 and 43 of this report).
- (c) Specific combustor performance including combustion efficiency and stability limits. (Note - Preliminary values are quoted in Fig. 41 of this report).
- (d) Significant parameters to be used by the fuel control system. (Note - See Section 5.2.4.2 above and Fig. 34 of this report).

5.2.5 Shutter Tests

The outlet nozzles may be alternatively considered as part of the propulsion system or of the aircraft control system. It is considered convenient to regard the mechanical development of the shutters as part of the propulsion system. For this development two rigs are envisaged.

5.2.5.1 Single Nozzle Shutter Development

A single nozzle segment containing one pair of nozzles complete with operating mechanism will be constructed and fitted to the back of the Viper engine for shutter tests. This will be the first completely representative shutter functioning test series and tests will be run up to the maximum operating pressure for the outer wing and to a temperature of about 700°C. This segment will be fitted in place of the exhaust fantail in the illustration of Fig. 37.

5.2.5.2 Eight Nozzle Outer Wing Segment

Combustion equipment for a complete 1/6th segment will then be supplied by the subcontractor and fitted to a prototype outer wing segment (manufactured as part of the P.V.704 company program), so that the shutters can be functioned to the full operating temperatures. Fig. 44 illustrates.

new



OPERATING CONDITIONS

| Altitude | Flight Mach No. | Inlet Pressure | Inlet Temp. | Inlet Casing Mach No. | Inlet Casing Velocity | Total Air Mass Flow | Air/Fuel Ratio | Total Fuel Flow | Total Fuel Flow Per Chamber | Pilot Fuel Flow Per Chamber | Main Fuel Flow Per Chamber | Pilot Atomising Pressure | Main Atomising Pressure | Pressure Loss | Combustion Intensity | | | |
|----------|-----------------|----------------|-------------|-----------------------|-----------------------|---------------------|----------------|-----------------|-----------------------------|-----------------------------|----------------------------|--------------------------|-------------------------|---------------|----------------------|-------------------------------|------|-------|
| K. FT | | P. S. I. A. | °K. | | FT/SEC | LB/SEC | | G.P.H. | G.P.H. | G.P.H. | G.P.H. | P. S. I. | P. S. I. | P. S. I. | % OF INLET PRESS. | MCHU/FT ² /HR/ATM. | | |
| | 0 | 16.8 | 308 | 0.112 | 129.4 | 643 | 41.9 | 6920 | 144 | 10.05 | 133.95 | 283 | 330 | 0.977 | 5.82 | 12.85 | | |
| * | 0 | 0.6 | 21.5 | 0.110 | 131.6 | 779 | 42.9 | 8170 | 170 | 12.18 | 157.82 | 416 | 458 | 1.117 | 5.19 | 11.85 | | |
| * | 0.8 | 25.7 | 348 | 0.110 | 135.0 | 909 | 43.7 | 9360 | 195 | 14.2 | 180.8 | 566 | 600 | 1.286 | 5.00 | 11.35 | | |
| * | 0.8 | 11.5 | 300 | 0.110 | 125.2 | 437 | 41.5 | 4740 | 98.7 | 6.82 | 91.88 | 131 | 155 | 0.659 | 5.73 | 12.85 | | |
| ∅ | 20 | 1.54 | 28.3 | 0.1185 | 152.0 | 1026 | 45.3 | 10180 | 212 | 16.04 | 195.96 | 723 | 707 | 1.501 | 5.30 | 11.25 | | |
| * | ∅ | 35 | 1.95 | 24.8 | 410 | 0.133 | 177.0 | 975 | 46.7 | 9400 | 196 | 15.23 | 180.77 | 650 | 600 | 1.556 | 6.27 | 11.85 |
| * | ∅ | 50 | 2.4 | 22.6 | 490 | 0.136 | 198.0 | 833 | 51.8 | 7230 | 151 | 13.0 | 138.0 | 474 | 350 | 1.265 | 5.59 | 10.0 |
| * | 70 | 2.4 | 8.6 | 490 | 0.136 | 198.0 | 317 | 51.8 | 2750 | 57.3 | 4.95 | 52.35 | 68.9 | 50.5 | 0.481 | 5.59 | 10.0 | |
| | | 3.0 | 17.6 | 630 | 0.120 | 198.0 | 505 | 63.4 | 3590 | 74.8 | 7.89 | 66.91 | 175 | 82.5 | 0.612 | 3.48 | 6.36 | |
| | 90 | 3.0 | 6.7 | 630 | 0.120 | 198.0 | 192 | 63.4 | 1360 | 28.3 | 3.0 | 25.3 | 25.3 | 11.8 | 0.233 | 3.48 | 6.36 | |

* FLIGHT PLAN CONDITIONS

∅ SPEED LIMIT CONDITIONS

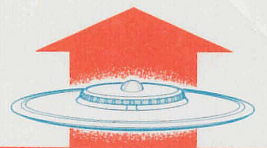

2056-1794-1

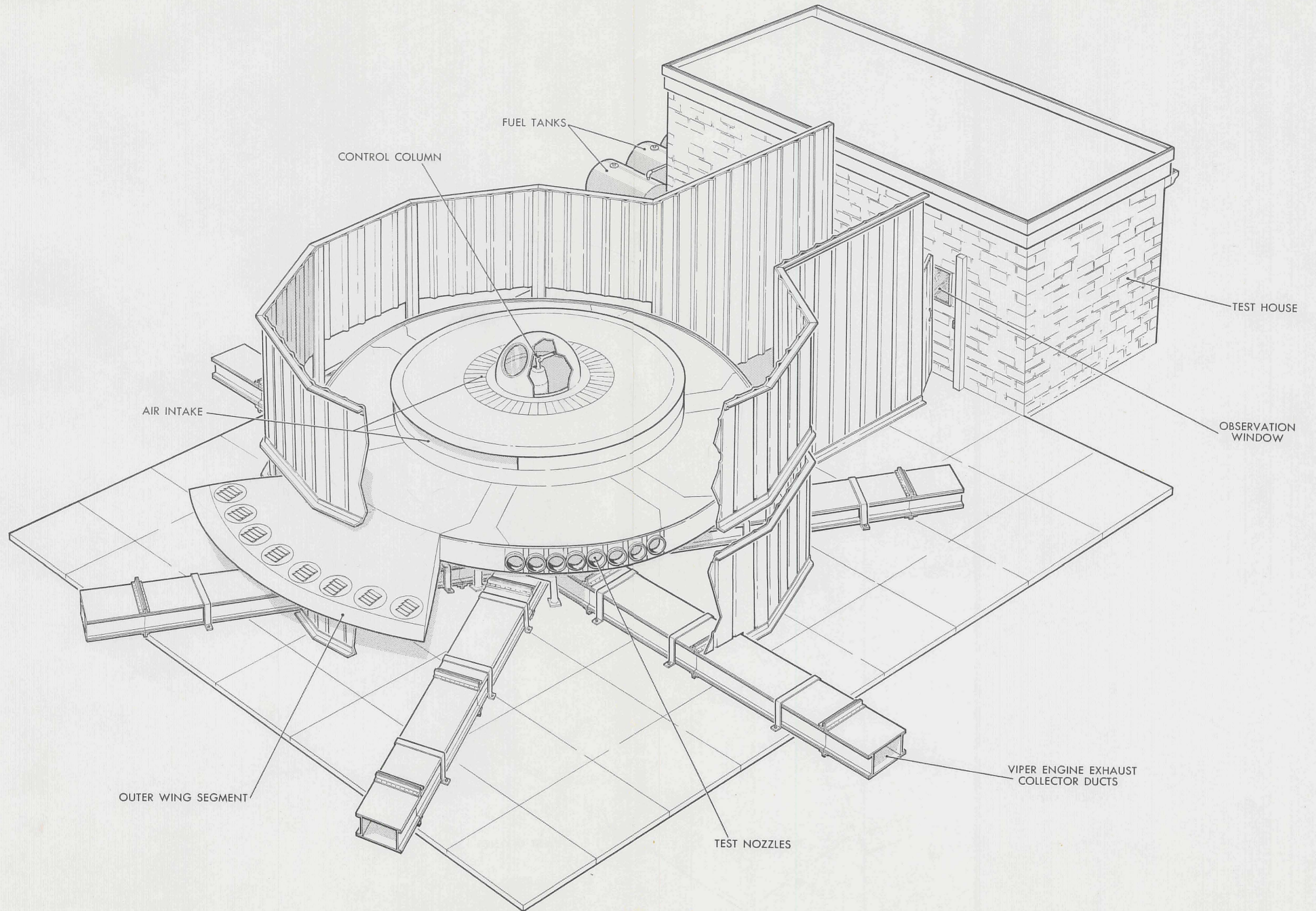

FIG. 44 SIX VIPER TEST RIG WITH OUTER WING AND COCKPIT

It is visualized that the qualification of the control shutters will be carried out on this segment, probably without after-burning to start with, followed by several stages at different temperature levels. The initial qualification of the control shutters will as far as possible be carried out concurrently with a type test for the propulsion unit in order to enable flight to begin at the earliest possible date.

new section

5.3 Propulsion System Specification and Report

In view of the unique integration of the propulsion system with the aircraft on Project 1794 the specification of the research aircraft and weapon system studies called for in Section 3.1 of this Planning Program will include details of propulsion system components; for example drawings (see p. 13) will be provided for the main rotors and also of the outer wing showing installation of combustor cans etc.

The propulsion system as a whole will be specified as a separate part of the propulsion report however, in addition to those parts appearing in the aircraft specification. This former specification will include -

- (a) Compressor map.
- (b) Turbine map.
- (c) Detail weight estimates for the components.
- (d) Presentation of performance parameters - thrust, mass flow and specific fuel consumption.
- (e) Combustor and fuel system specification.
- (f) Control system design details.

The propulsion report will specifically include the following items:

- (a) Experimental verification of the performance of the compressor.
- (b) A summary of the calculations for matching the components of the propulsion system.
- (c) A discussion of stall margins and control action.

5.4 Spare Viper Engines

The Viper engines which will initially be fitted to the six Viper test rig will be standard Viper ASV8 "Provost" type engines. For the first prototype however, "Uprated" ASV8 engines - offered by the manufacturers by means of simple modification to the flow control unit - are required.

Additionally to the flow control unit change, further modification to the prototype engines is desirable at some point, principally to incorporate the new air intake casting and remote accessories gearbox shown in Fig. 4.

Orders have therefore been placed by Avro Aircraft Limited for eight standard ASV8 engines - seven to be delivered by April 1957 and one to be retained by the manufacturers for modification and installation of the new accessories gearbox. Thus the six Viper rig can initially be operated with one spare engine, a second becoming available in modified form in due course. From the point of view of operating the test rig this is regarded as a marginal arrangement and for the prototype the remaining seven engines have to be returned for overhaul and modification at completion of rig running.

Additional spare engines are therefore most desirable not only to provide increased contingency for rig running but to allow its continuance during modification of the first seven engines and thus avoid considerable delay. However, in view of the existing order, it is clear that additional spares should now be provided in the modified form shown in Fig. 4. Bearing in mind the obvious desirability of having a complete set of modified engines delivered to a given date it is evidently necessary to order a further 6 engines of this type.

The modified engines are, of course considerably more expensive than the standard. In view of the fact that the modifications are not strictly required for rig running it is considered inappropriate that the USAF be asked to bear the cost of these and thus the amount quoted in this proposal is for the set of standard engines which will be used first in the six Viper test rig.

5.5 Work Chart, Scheduling and Cost

The work chart of Fig. 45 illustrates the relationship of the items mentioned and denotes those which are part of the P.V. 704 items. Scheduling is given in Fig. 46. Cost and manhour estimates are shown on pages 95-108.

2119-1794-1

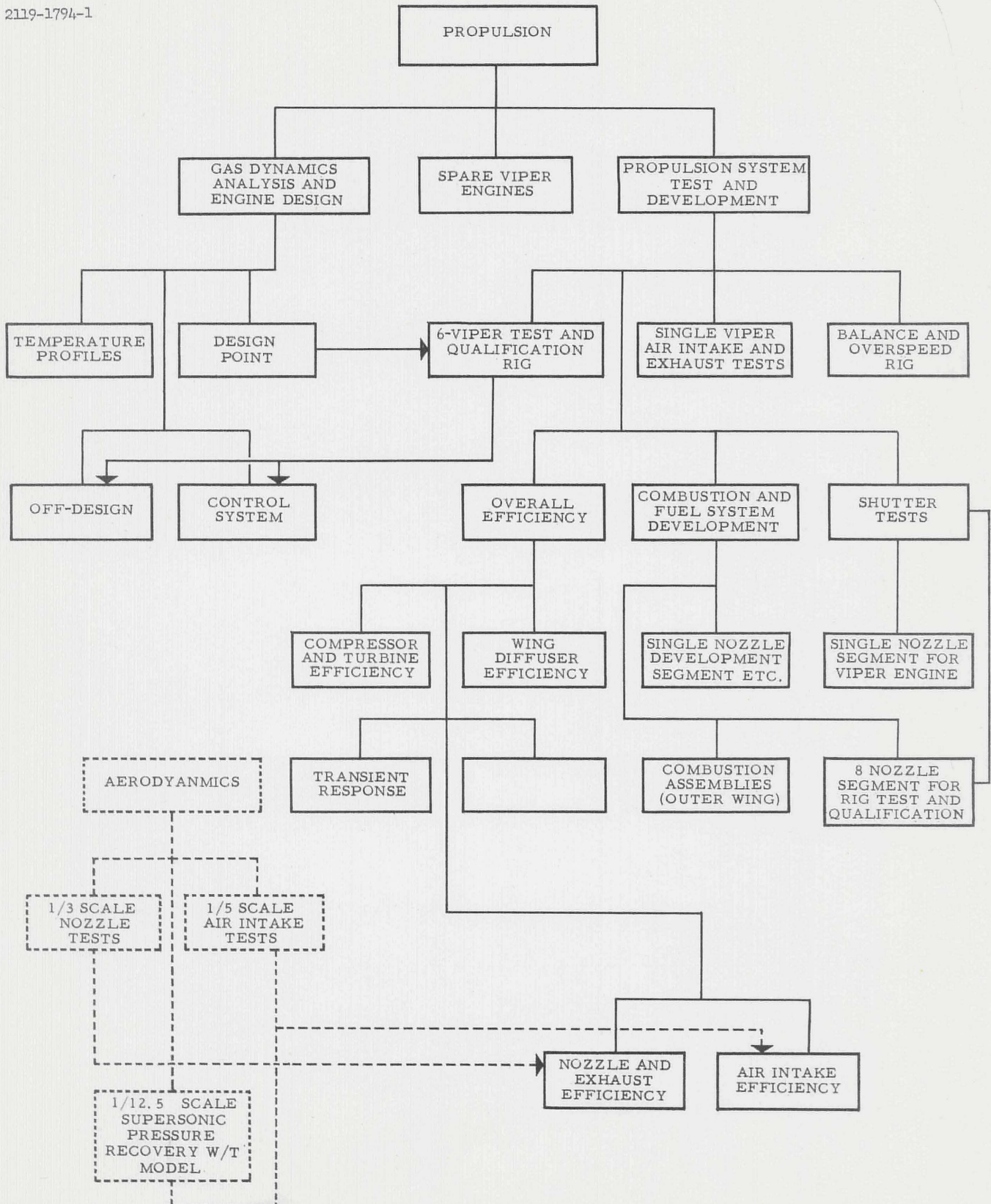

FIG. 45 WORK CHART - PROPULSION

6. STABILITY AND CONTROL

As stated in the Introduction, pitch stabilization through the controls is essential in this aircraft and the change in jet direction as the aircraft pitches performs the same function as the fixed stabilizer on a conventional aircraft. In order that the significance of the work proposed in this section may be fully appreciated a brief explanation of the central stability problem and description of the proposed stabilizer is given here as follows:

The aircraft centre of gravity is in the middle whereas the neutral point for the wing varies from approximately 20% to 45% of the root chord, depending on Mach No. and angle of attack; and thus with controls fixed the aircraft is statically unstable. At high subsonic speed in particular, where the negative margin is greatest, a pilot would not be able to operate the controls quickly enough to balance the aircraft and keep it from pitching up out of control; and a stabilizing mechanism with a much faster response is required to operate the controls instead; leaving the pilot with a monitoring control, which will effectively set the attitude the stabilizer is to work to, and thus determine the flight path.

The stabilizing mechanism proposed is illustrated by the diagram of Fig. 49. The controlling element, the shutters in the exhaust ports, is a servo, since it only requires a small effort to move them, and this produces a large force on the aircraft by re-directing a powerful jet; thus it will be possible to get large changes in pitching moment very much faster than would be possible if the moment were produced by moving a heavy elevator.

The shutter position is controlled by a pneumatic jack which holds the shutter closed to a given angle against the pressure inside the wing. The pressure in the jack is determined by the stabilizer, which thus sets the shutter angle and main jet efflux, altering the top and bottom differentially i. e. as the upper is closed the lower will open and vice versa.

The pressure to the jacks controlling the pitching shutters is made to depend on the angle of attack and forward speed, and on the rate of pitch of the aircraft in the following manner:

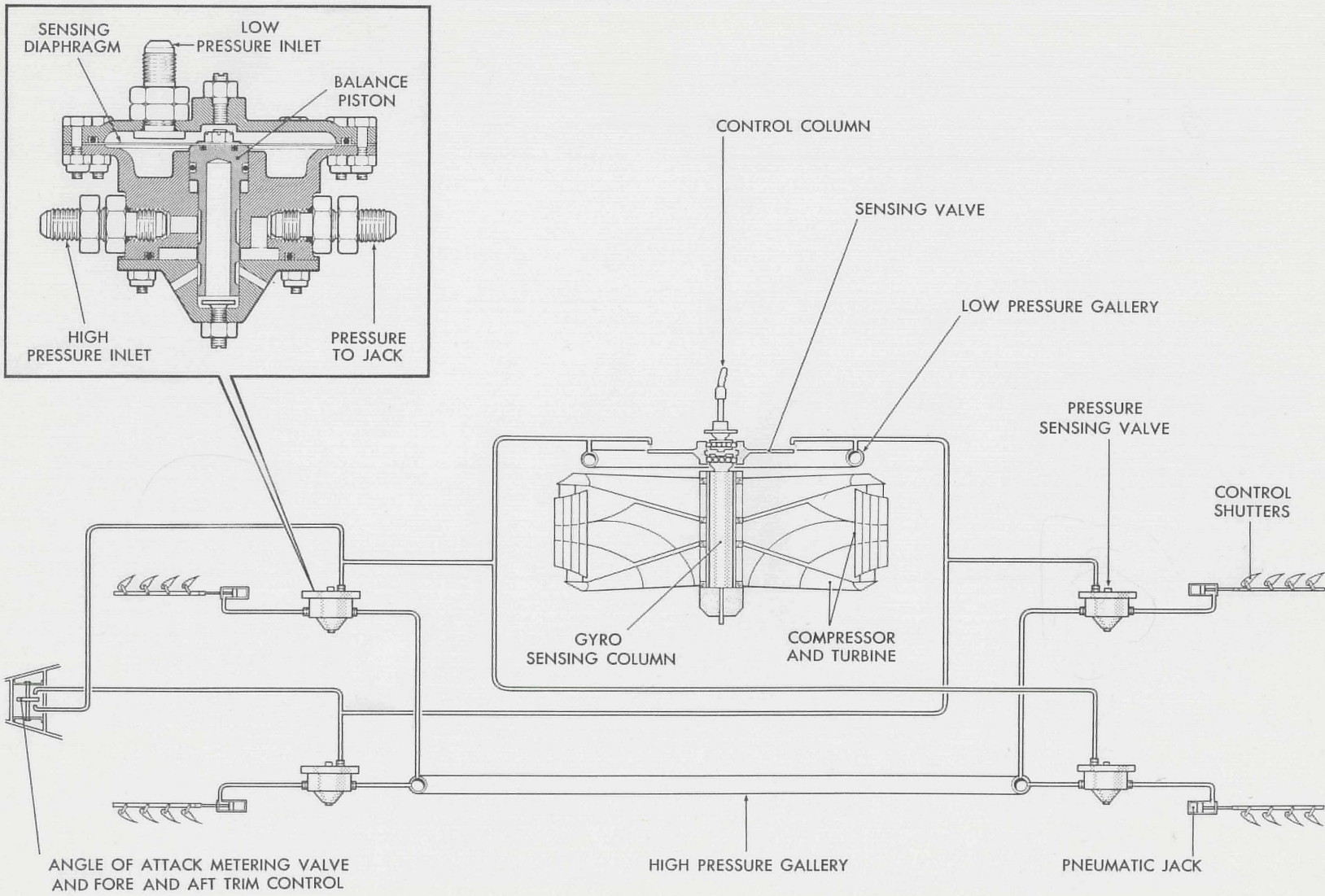
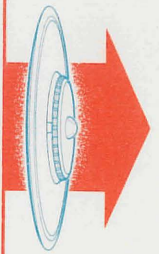

FIG.49 SCHEMATIC OF SHUTTER CONTROL SYSTEM

SECRET

if the angle of attack changes the pressure differential between the top and bottom of the wing will alter to move the diaphragm (shown in Fig. 49) and thus alter the leak and change the sensing lines' pressure; and also because if the aircraft is pitching the main rotors will precess towards each other (since they are contra-rotating) and in straining the main mounting shaft will rock the sensitive plate shown in the diagram and similarly change the sensing lines' pressure.

The sensing lines' pressure does not operate the shutter jacks directly but is fed to the amplifier valves, one of which is shown sectioned in the upper left of the diagram. The purpose of these valves is to control the high pressure (0 to 1000 psi) jack operating air according to the low pressure (0 to 30 psi) air fed to it by the sensing line.

In order to control the aircraft attitude it is only necessary for the pilot to bias the sensing line pressure by means of the cockpit control stick and the aircraft will respond, without of course, interfering with the action of the stabilizer to control any deviations from the new attitude demanded - by itself making further changes in the sensing line pressure.

6.1 Analysis

The principal effort under this head will thus be concentrated on the analysis of flight characteristics of the prototype vehicle using data from wind tunnel and control system component performance tests. These studies may be considered under the following heads.

6.1.1 In-flight Characteristics

Considerable data already exists on the subsonic aerodynamic control characteristics in the 'in-flight' configuration: data on the control characteristics at supersonic speeds is however sparse and at transonic speeds non-existent and further tests under these heads have been proposed in Section 4. These will be combined with the measured transfer function of the control system to produce the overall in-flight characteristics of the aircraft over the entire range of speed and altitude. In the proposed program there will still be no direct data on the aerodynamic and control characteristics in roll and yaw but it is nevertheless believed that the vital problem is that of satisfactory stability and control in pitch and estimated values will suffice for the former.

6.1.2 Hovering and Transition

Considerable further data on the aerodynamic and control characteristics in the hovering and transition phase are required and further tests for this purpose have been described in Section 4.

Results of these tests, it is hoped, will be available by the time reliable frequency response data on a fully representative shutter test has been obtained and a thorough analysis of the stability and control in the hovering and transition phase will be made as soon as they are available.

6.1.3 Flight Limitations

The flight limitations imposed on the aeroplane by the available control power will be re-examined in the light of further supersonic and also transonic tests and with consideration of the effects of control system transfer function on gust response.

6.1.4 Stall and Post-stall

In view of the possibility of inadvertent or unavoidable 'forced-stall' where control power is at a minimum or if gust consideration combined with control response should prove critical, careful integration will be made of the motion of the aircraft through such manoeuvres. Particular attention must be paid to the maximum normal acceleration experienced by the aircraft and the length of time for which high 'g' is sustained.

6.1.5 Safety and Reliability

Since control of the aircraft, at least at moderate to high subsonic speeds, is completely dependent on the operation of the stabilizer, it is clear that a degree of reliability as good as that of a conventional powered flying control system must be provided. It is for this reason that the pneumatic system with entirely mechanical components has been chosen; and functional tests to develop the shutters to the required integrity will be carried out on the rigs discussed in Section 5.2.5. The stabilizer elements will be added to these rigs and to the original shutter rig as subsequently explained in Sections 6.2.2, 6.2.3 and 6.2.4 and similarly developed. Additionally, studies will be made of the failure characteristics of the system and sufficient duplication will

be provided where inadequate operational envelopes are found to exist with the limited control remaining after failure. The requirements of specification MIL-8785(ASG) will be followed as far as they are applicable.

6.1.6 Increase of Static Margin

Study will also be afforded toward the possibility of reducing the static instability of the basic aircraft by means of significant change in the centre of gravity and possibly by limited alterations to the planform, whose effects can be readily determined without recourse to detailed design study.

6.2 Tests

Apart from wind tunnel tests to determine control characteristics, certain other tests specifically to determine control system component performance and stability behaviour are visualized as follows:

6.2.1 Unit Development

The first problem encountered is that of developing satisfactory functioning of the cockpit valve, angle of attack signal input valve, signal mixing, pressure control valve and shutter jack units.

Static tests are in progress to develop satisfactory functional performance and linear response on these various items.

6.2.2 Frequency Response Rig No. 1

A rig for measuring the frequency response characteristics of an approximately representative pneumatically controlled shutter system has already been constructed and is illustrated in the photograph of Fig. 50 and the schematic perspective of Fig. 51.

Tests will be carried out on this rig with the latest system components at the earliest practicable stage of development (as above), with representative control runs, to get the earliest possible idea of the control system transfer function. Instrumentation will consist of linear transducers at oscillator input and shutter output with pressure transducers at suitable points in the system, together with a strip recorder.

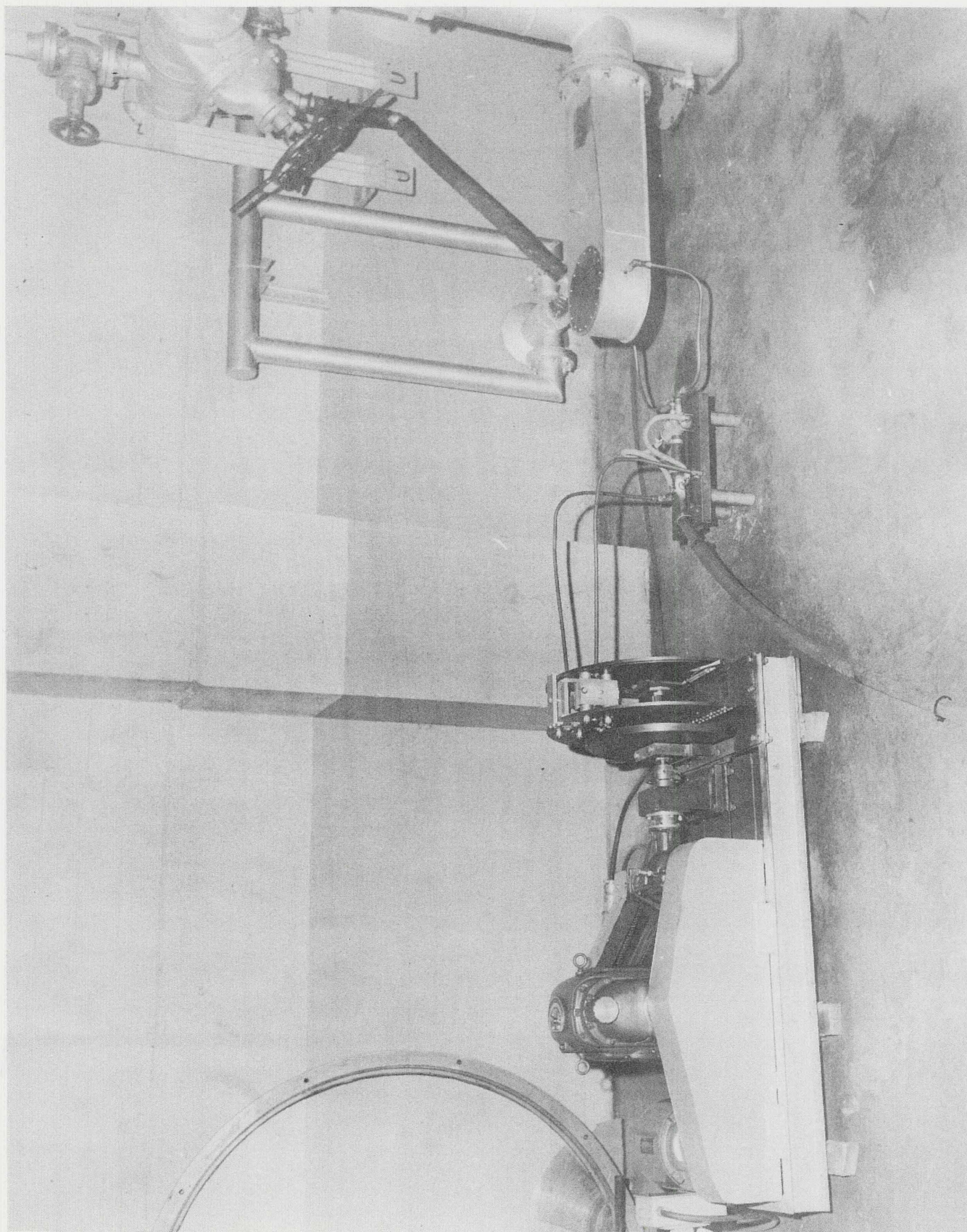
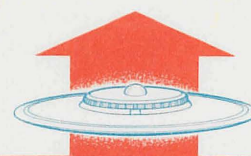
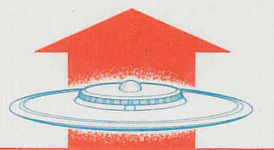

FIG. 50 FREQUENCY RESPONSE RIG NO 1



1248-1794-2

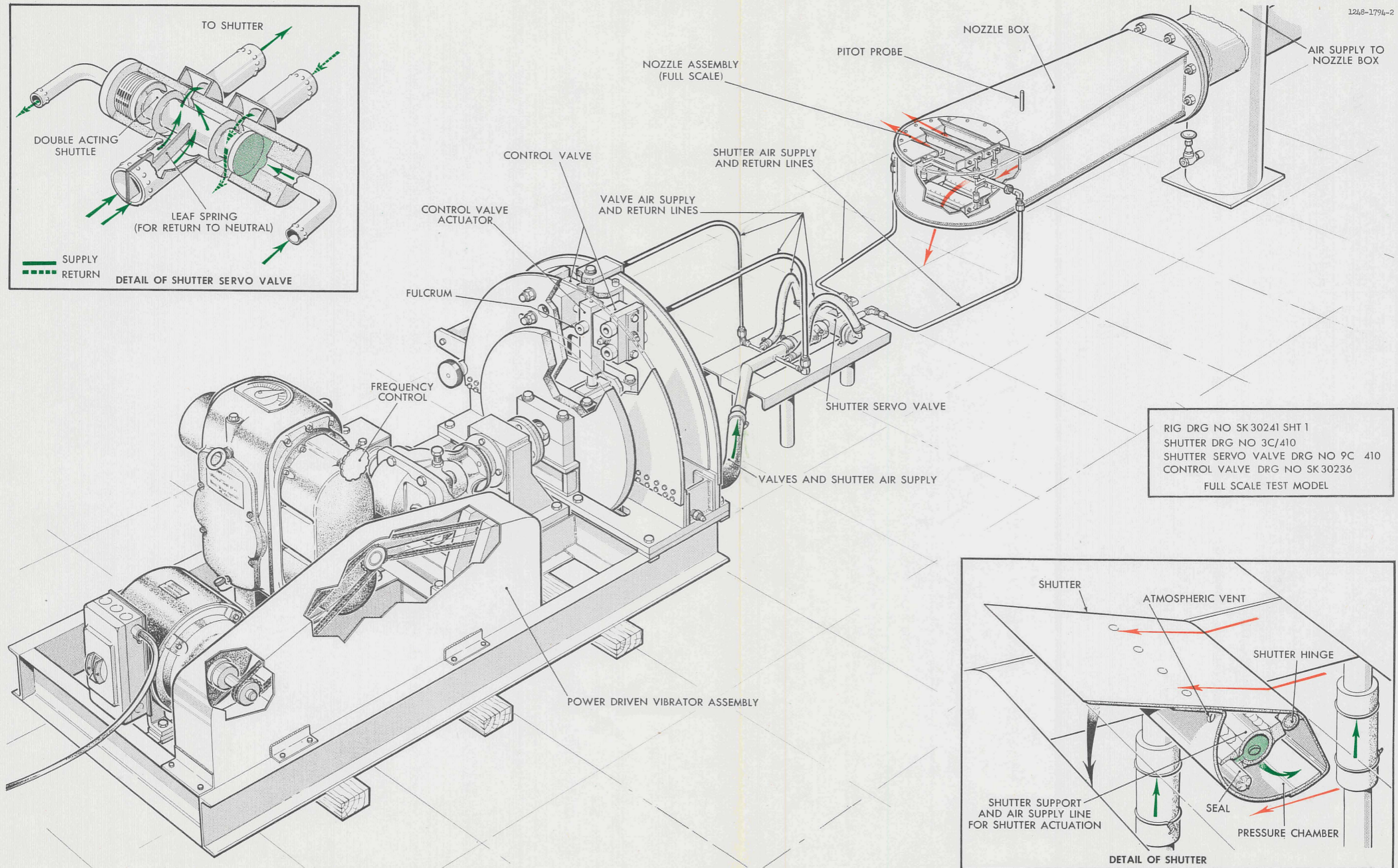

FIG. 51 FREQUENCY RESPONSE RIG NO. 1

The effect of varying the moment of inertia of the shutters will be investigated.

6.2.3 Single Nozzle Segment Frequency Response Tests

Frequency response tests will then be carried out on the single nozzle segment described in Section 5.2.5.1 to obtain control system transfer function for a completely representative set of shutters at the earliest possible date. Control lines, valves, etc. will be as representative as possible.

6.2.4 Eight Nozzle Segment Frequency Response

Control system transfer function will finally be checked on the 1/6th segment containing eight nozzles described in Section 5.2.5.2; with a complete pneumatic system installed as it will be on the aircraft including a control column to which an oscillating input will be applied (see Fig. 44). Recordings will be taken of output of each of the separate pairs of shutters for the whole segment.

6.2.5 In-flight Mechanical Analog

In view of the importance and novelty of the mechanical stabilizer it is considered that every effort should be made to represent aircraft flight motions in a simulator which employs the actual components of the stabilizing system; at least those which are known to be possible causes of response delay.

A mechanical analog is visualized for tests of this nature which will employ the shutter box shown in Figs. 50 and 51. The proposed rig is illustrated by the sketch of Fig. 52. The aircraft is represented by a beam (fitted with shields) pivoted on the box and pitched by the impingement of the jet on this shield and by an adjustable spring representing an aerodynamic disturbing moment proportional to the angular displacement. This displacement is sensed by air bleed sensing lines representing the angle of attack valve. A rate gyro is mounted on the shield and its precession is again felt by air bleed sensing lines which represent the cockpit valve. The veritable aircraft system is then interposed between sensing points and shutters and thus a disturbance of the shield will be corrected by the jets in a truly analogous manner.

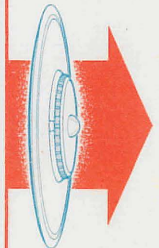

2133-1794-1

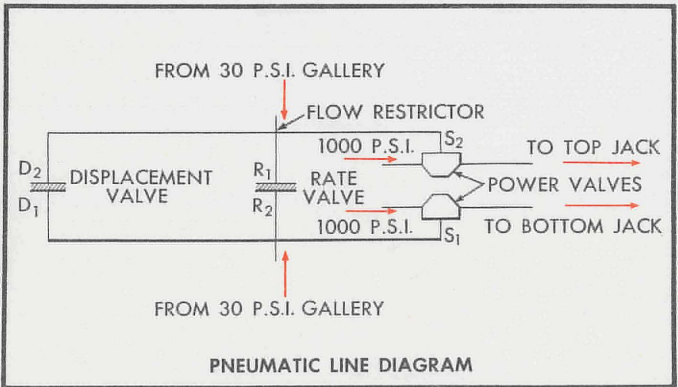
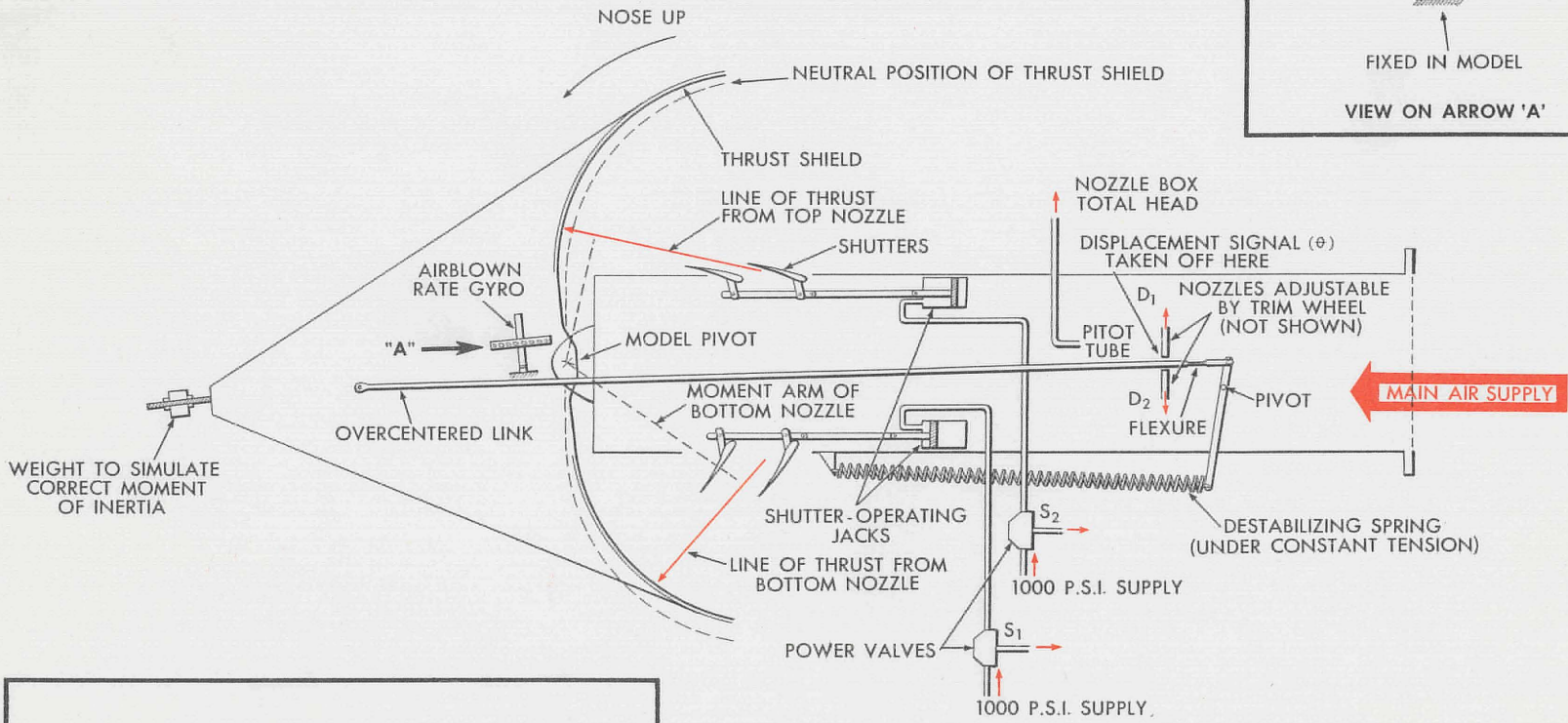
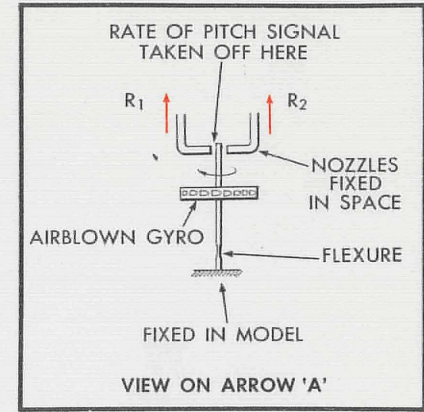

FIG. 52 SCHEMATIC OF CONTROL SYSTEM MECHANICAL ANALOG

SECRET

Adjustments on the rig will be provided for varying the moment of inertia, spring tension and rate and displacement signal gains.

It will be appreciated that as presently conceived the rig is only in two degrees of freedom. In due course it may be possible to simulate angle of attack instead of angle of pitch, nevertheless it can be shown that for some important flight cases the difference is not sufficient to destroy the analogy. The rig will contain all the important time lags of the system and additionally simulates the aerodynamic lag of the jet force.

6.2.6 Hovering Analog

A similar analog to represent the motions of the aircraft hovering in the ground cushion is equally desirable.

However, in this case, it is the motions of the aircraft resulting from its proximity to the ground that are important and freedom in rise and fall as well as freedom in pitch and roll is desirable. Hovering simulation with control can be carried out by electrical analogy and it is planned to undertake a study of this nature as soon as more reliable control data in the ground cushion together with control transfer function have been obtained. At the same time it is thought worthwhile to attempt a mechanical analogy at an early stage with control and with a rate signal for artificial stability augmentation. This can be done with the existing ground effect rig of Fig. 28, if it can be shown that the reflected forces on the ground are sufficiently close to those on the aircraft for small motions; in which case a freely pivoted board can be made to represent the aircraft.

6.3 Work Chart Scheduling and Cost

The work chart of Fig. 53 on the following page illustrates the relationship of the items mentioned and the schedule of Fig. 54 will be seen to be inter-related with those of previous sections. Cost and manhour estimates are shown on pages 95-108

2118-1794-1

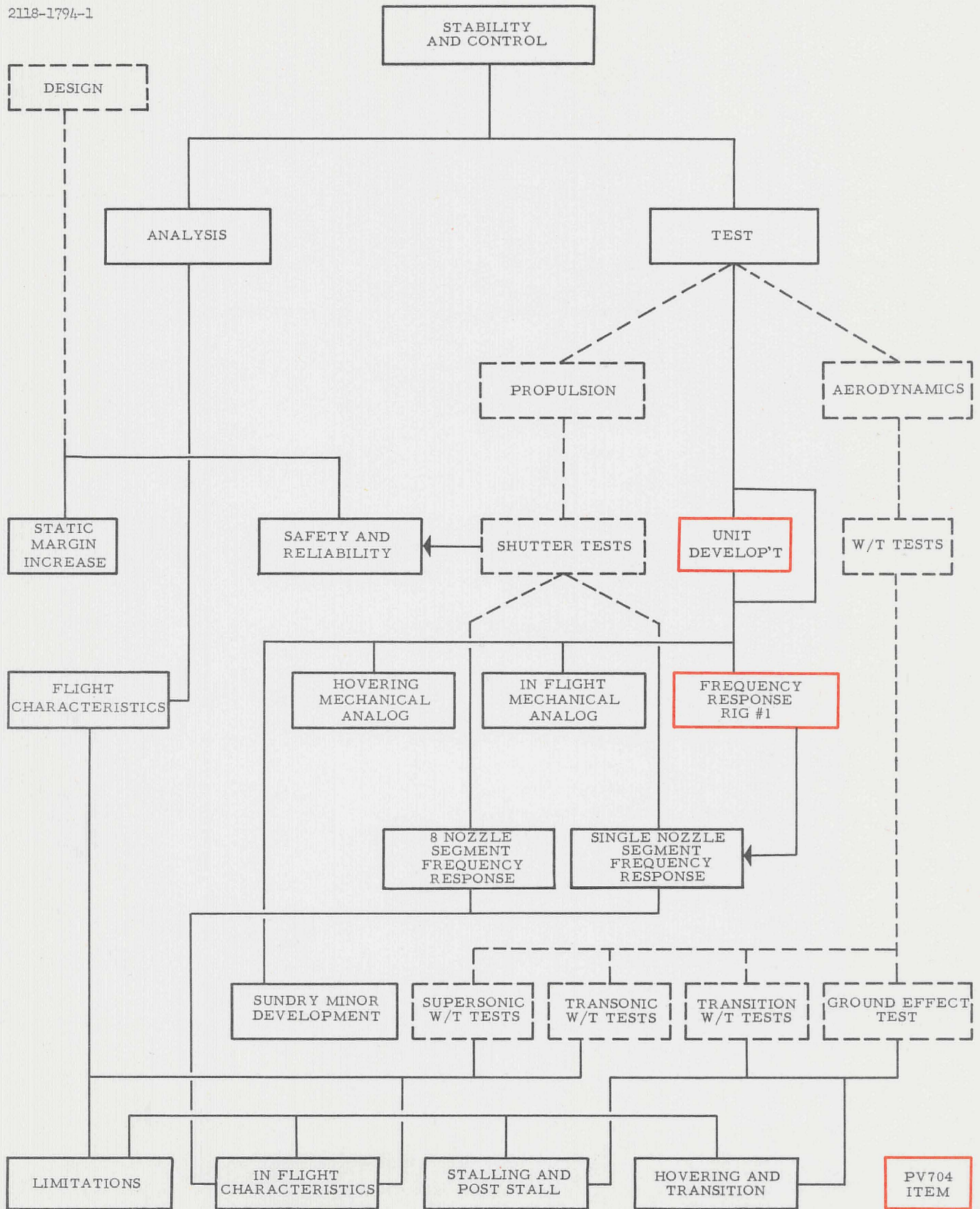

FIG. 53 WORK CHART-STABILITY AND CONTROL

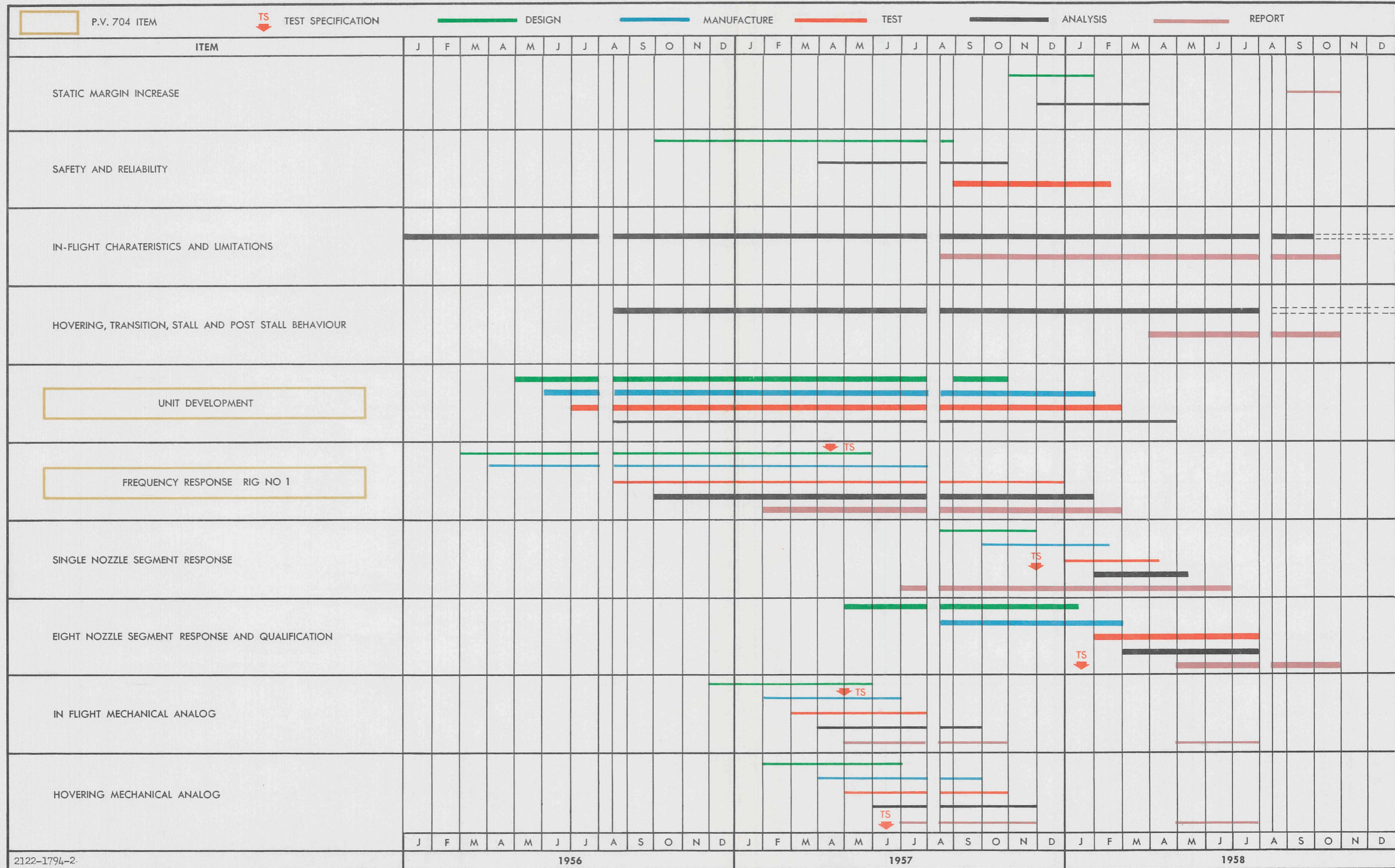

FIG. 54 WORK SCHEDULE CHART-STABILITY AND CONTROL

727-1794-1

7. STRUCTURES

The prototype P.V. 704 aircraft is being designed to the July 1956 issue of ARDC M80-1. Stressing is in accordance with the applicable requirements of MIL-S-5700 through MIL-S-5711 and such other incidental requirements are as covered in ARDC M80-1.

Additionally the following design criteria are being applied:

- (a) The aircraft is being designed to a maximum normal acceleration of $\pm 10g$ at all speeds within the placarded flight envelope.
- (b) The aircraft is being designed to a maximum rate of roll or pitch of 3 radians per second.
- (c) The maximum differential pressure between the interior of the wing and ambient is limited to 10 lb./sq. inch.

This places a restriction on the maximum flight speeds that can be used at most altitudes and the limit is shown on the graphs of Figs. 42 and 43.

The work proposed under the heading of Structures may be itemized as follows:

7.1 Analysis

7.1.1 Strength and Stiffness of Research Aircraft

Because of the circular wing planform, intake arrangement and jet control, surface pressures are difficult to estimate for this aircraft and should be obtained from tests as proposed in Section 4. Results of such tests will not however be available for a considerable time and for preliminary analysis estimated values will be used.

The work chart of Fig. 57 illustrates the breakdown of analytical work planned for the research aircraft stressing, indicating the various structural units that may be considered separately and form the subject for separate reports.

7.1.2 Stress Analysis for Weapon System Study

In addition, as stated in Section 3, preliminary stress

2212-1794-1

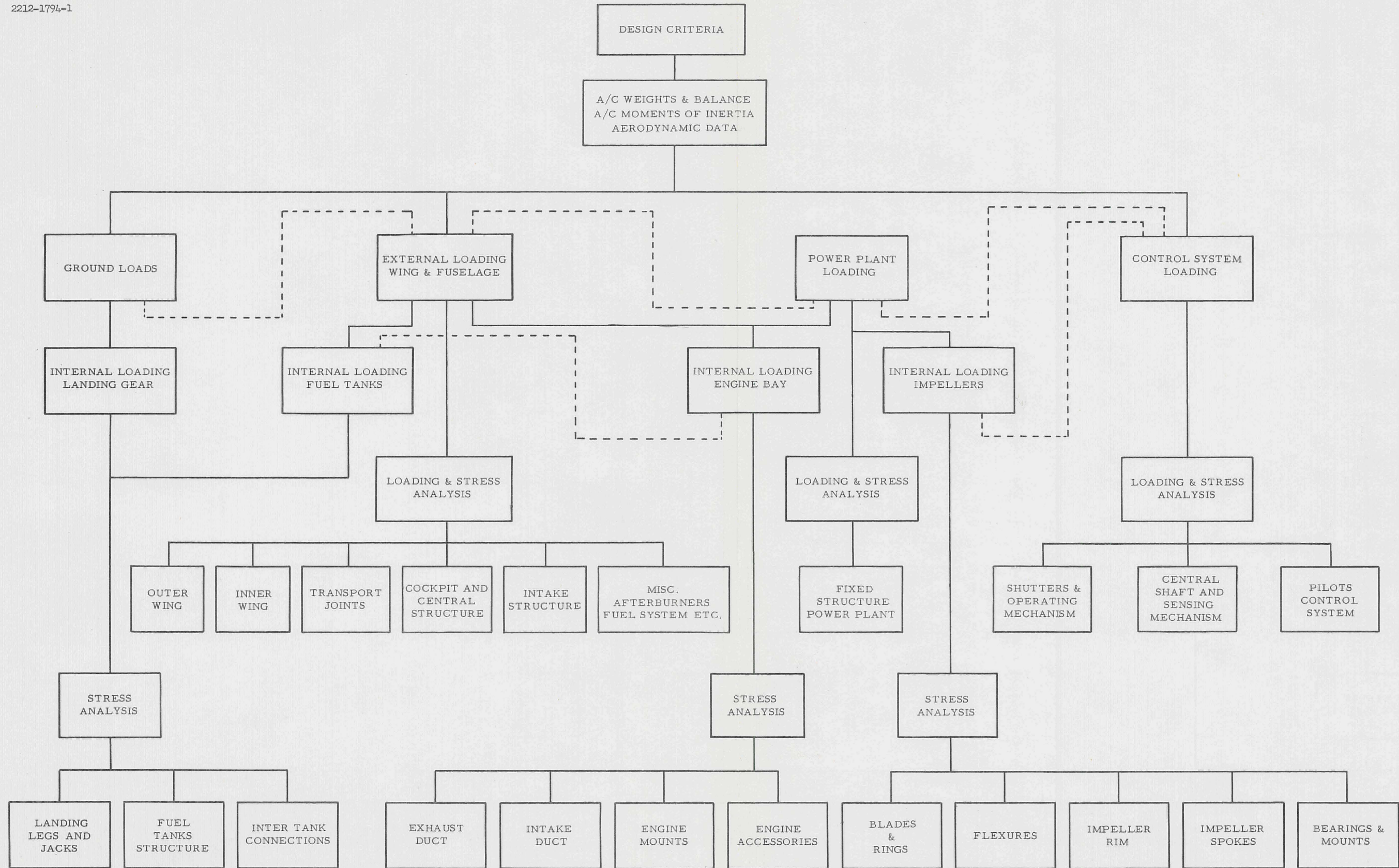
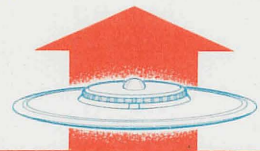

FIG. 57 PROPOSED STRESSING REPORTS FOR P.V. 704



analysis will be undertaken for the weapon system aircraft design study required with analysis of temperature effects. The work chart of Fig. 58 illustrates the approximate content of work visualized for this study.

7.1.3 Flutter, Vibration and Noise

A characteristic of low aspect ratio wings is that the modes of deformation of the wing due to periodic excitation cannot be reliably calculated, except for certain simple and idealized cases. The present structure of Project 1794 is not axially symmetric so that the same considerations apply and it is considered unlikely that an attempt to calculate the natural modes would yield useful results. It will therefore be necessary to carry out resonance testing of the entire aircraft configuration.

Although the modes of deformation can be so determined it is still necessary to determine the flutter derivatives and although these derivatives are known with fair accuracy for conventional wings, in that case they are derivatives of angular and linear displacement, based on the assumption of a rigid wing section. However it is clear that for a circular planform, the principal characteristic of classical flutter is the deformation of the wing section, a problem not previously investigated. In effect, the information required concerns the pressure distribution about the wing and its variation with deformation mode and frequency. Whereas theoretical estimates of the pressure distribution derivatives could be made it would probably be simpler to manufacture and test in a wind tunnel a model which is aerodynamically to scale and dynamically correct for the most important modes.

It is considered that even this would be a considerable undertaking which can hardly be justified at the present stage.

Thus it is felt that the best policy in this regard will be to first carry out shake tests on the complete prototype aircraft to determine both the modes of deformation and amplitude ratios at any important resonant frequencies that are found.

At this stage the possibility of constructing a wind tunnel flutter model will be considered.

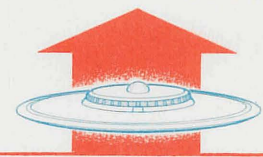

2213-1794-2

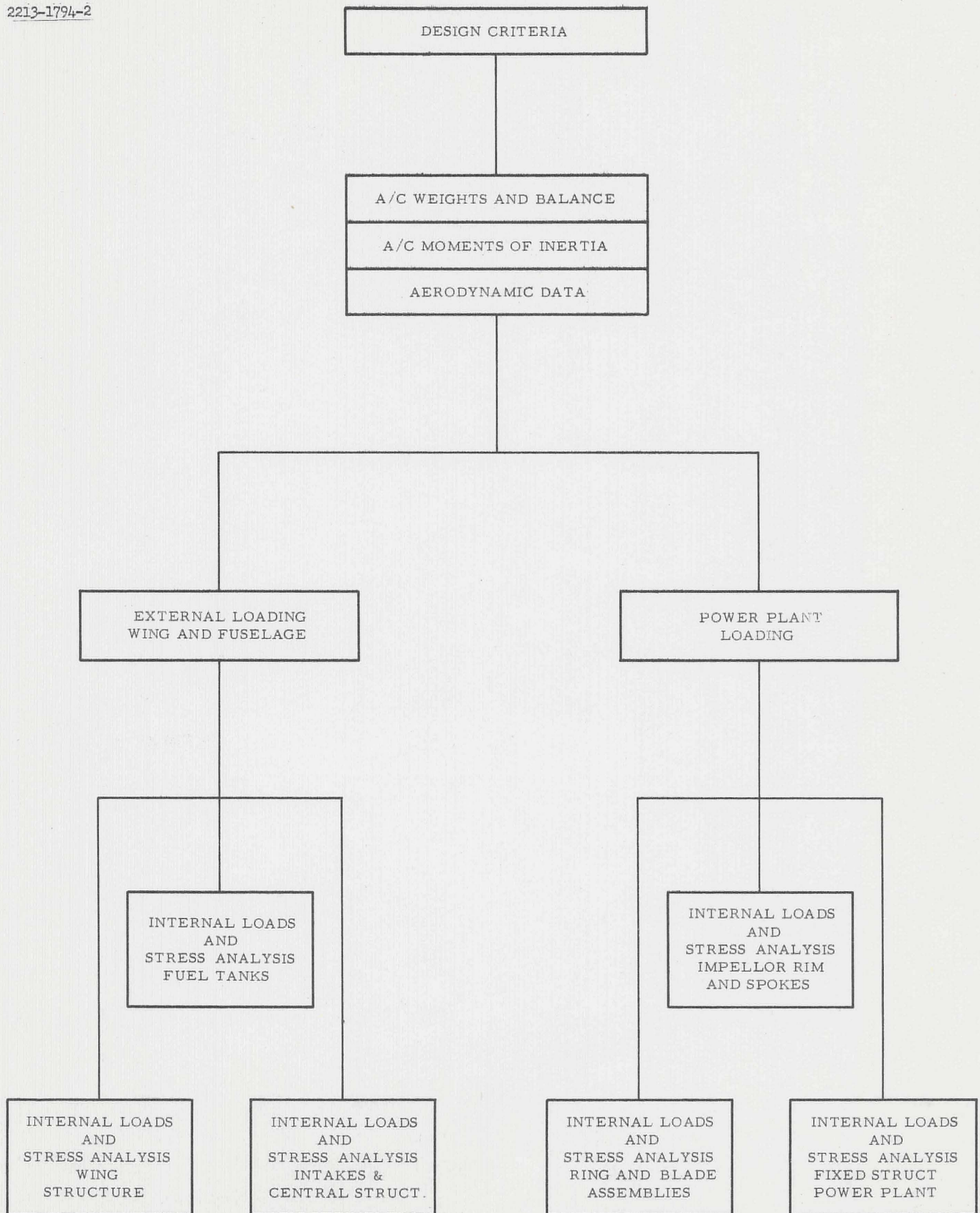

FIG. 58 PROPOSED STRESSING REPORTS FOR DESIGN STUDY

A further possible cause of trouble appears to be that of fatigue failure due to high frequency vibrations set up by the flow within the aircraft itself and a vibration test and analysis will be carried out on the prototype aeroplane as soon as practicable by probing the structure at numerous points with the engine operating. Such analysis will include sound pressure level and frequency bands.

7.2 Tests

7.2.1 Aircraft Shake Tests

Shake tests of the completed prototype aircraft will be carried out as outlined above.

Apart from the central engine rotor the principal sources of vibration are expected to be combustor pressure pulsation and flow separation in ducts and behind the air intake. So far as is possible these will be investigated on the six Viper test rig, and during combustion development, in order that the general order of the forcing frequencies will be known when resonance testing the first aircraft.

7.2.2 Vibration and Noise Measurement

The purely resonant phenomena such as blade and duct vibration will be investigated primarily on the first completed aircraft before flight trials commence, as outlined above. In the special case of the central turbine and compressors, individual blade resonance will be determined and provision can be made for strain gauging compressor and turbine blades as explained in Section 5, but present policy is to ignore vibration phenomena unless they cause structural failure.

Sound level measurements will be made on the completed prototype aircraft to determine the near, far and pilots' noise spectrum.

7.2.3 Strength Tests

Certain static tests to determine the strength and stiffness of selected critical items will be carried out, particularly directed at those parts of the structure which have to support a large differential pressure, e. g. the fuel tanks and outer wing panels. Other such tests of relatively minor nature will probably be required for the prototype.

In due course, and before the prototype aeroplane can be flown to speeds at which high loads can be encountered large scale structural tests will be carried out, but this does not form part of the present program.

7.3 Work Chart Scheduling and Cost

A chart illustrating the work outlined in this section is presented in Fig. 59 and an approximate schedule is given in Fig. 60. Cost for the stress analysis required for the weapon system design study is covered in Statement of Work Sub Part 1.1.9 (reference Section 3 of this report).

2115-1794-2

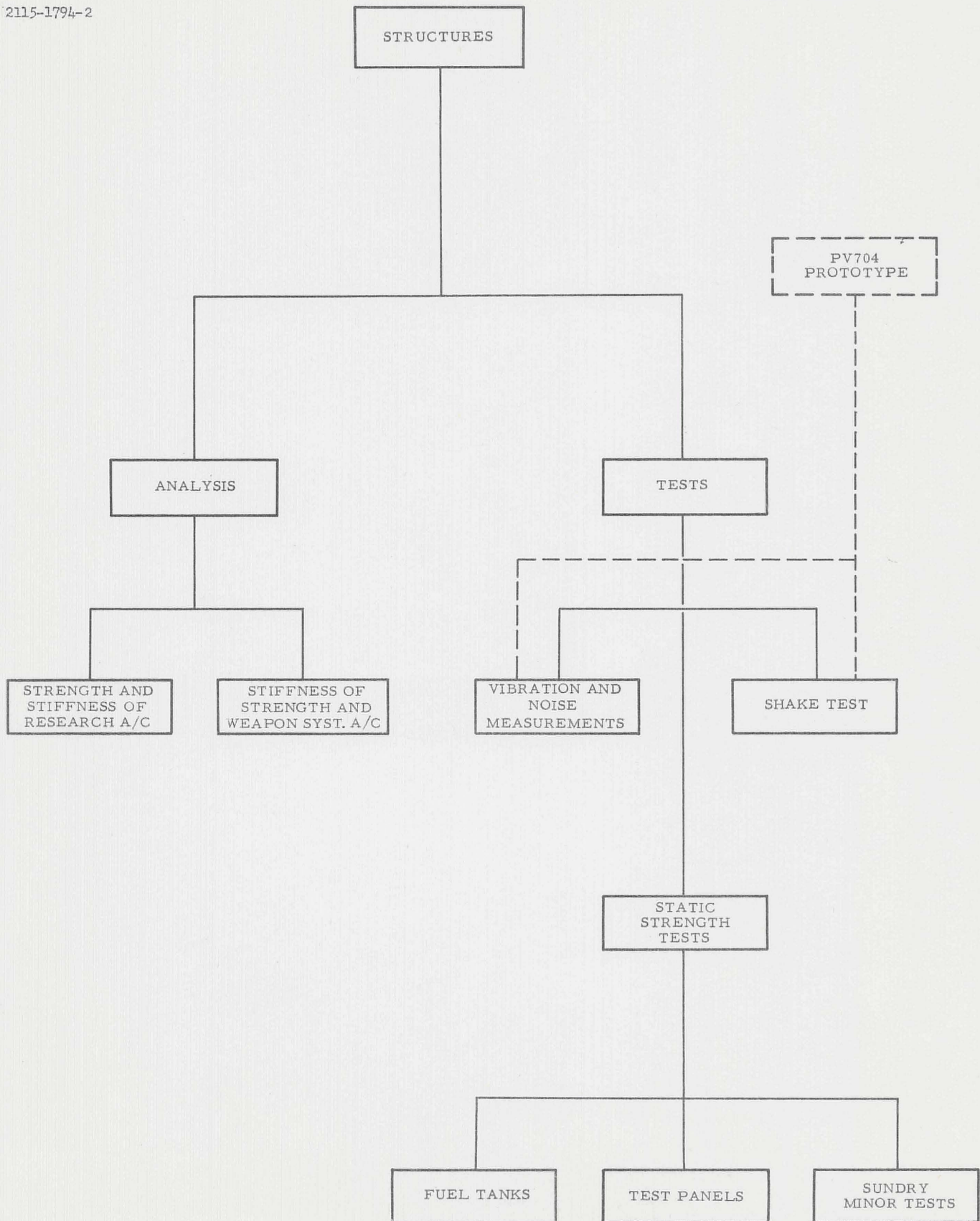

FIG. 59 WORK CHART-STRUCTURES

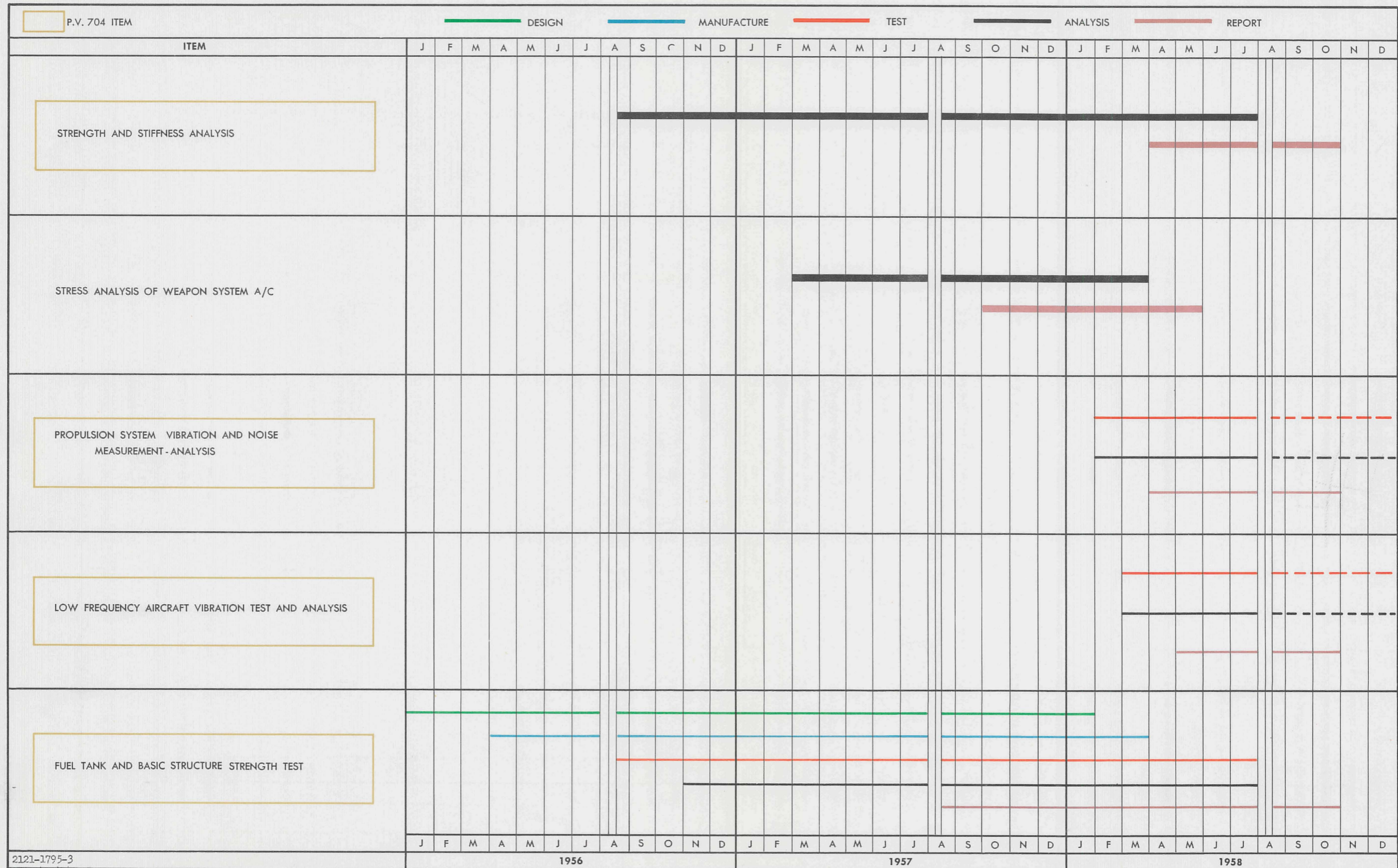

FIG.60 WORK SCHEDULE CHART - STRUCTURES

727-1794-1

8. REPORTS AND CONSOLIDATED WORK AND COST CHARTS

8.1 Program Planning Report

Ten copies of this program planning report are now submitted to the Commander Detachment #1 Hq. ARDC, Attention: RDZSBA, Wright AFB, Ohio.

8.2 Test Specifications

Detail specifications of all tests outlined in the program planning report, including those which form part of the company sponsored program will be submitted to Hq. ARDC, Attention: RDZSBA. Test specifications for the USAF items will be submitted for approval in advance of tests. Test specifications will provide information on test objectives, facilities, model characteristics, test condition, instrumentation requirements, data collection and reduction etc. Test specifications will be furnished in accordance with the work schedule charts in this report (designated TS on the charts).

8.3 Bi-monthly Progress Reports

Ten copies of a bi-monthly progress report will be furnished by the twentieth day of the month following the reported two month period, representing a summary of: work performed, percentage of task accomplished, results obtained, problems encountered and the budgetary status of the program. These will be delivered to Hq. ARDC, Attention: RDZSBA.

8.4 Technical Reports

Six technical reports will be submitted as follows:

8.4.1 Summary Report

The summary report will contain -

- (a) An Introduction which includes historical background and statement of purpose of objectives,
- (b) Discussion of the design concept,
- (c) A presentation of important results,

- (d) An evaluation and interpretation of these results,
- (e) Conclusion and,
- (f) Recommendation.

8.4.2 Design and Performance

A design and performance report covering the work outlined in Section 3.

8.4.3 Aerodynamics

An aerodynamics report covering the work outlined in Section 4.

8.4.4 Propulsion

A propulsion report covering the work required by Section 5.

8.4.5 Stability and Control

A stability and control report covering the work outlined by Section 6.

8.4.6 Structures

A structures report covering the work outlined in Section 7.

25 copies of each of these technical reports will be furnished to Hq. ARDC, Attention: RDZSBA, by not later than October 31, 1958.

8.5 Consolidated Work and Cost Chart

Fig. 65 is a consolidated work chart for all the work outlined in this report, indicating the tie-in between the USAF and company sponsored program, while estimates of costs and manhours are shown on charts and tabulated lists on pages 95-105.

2100-1794-2

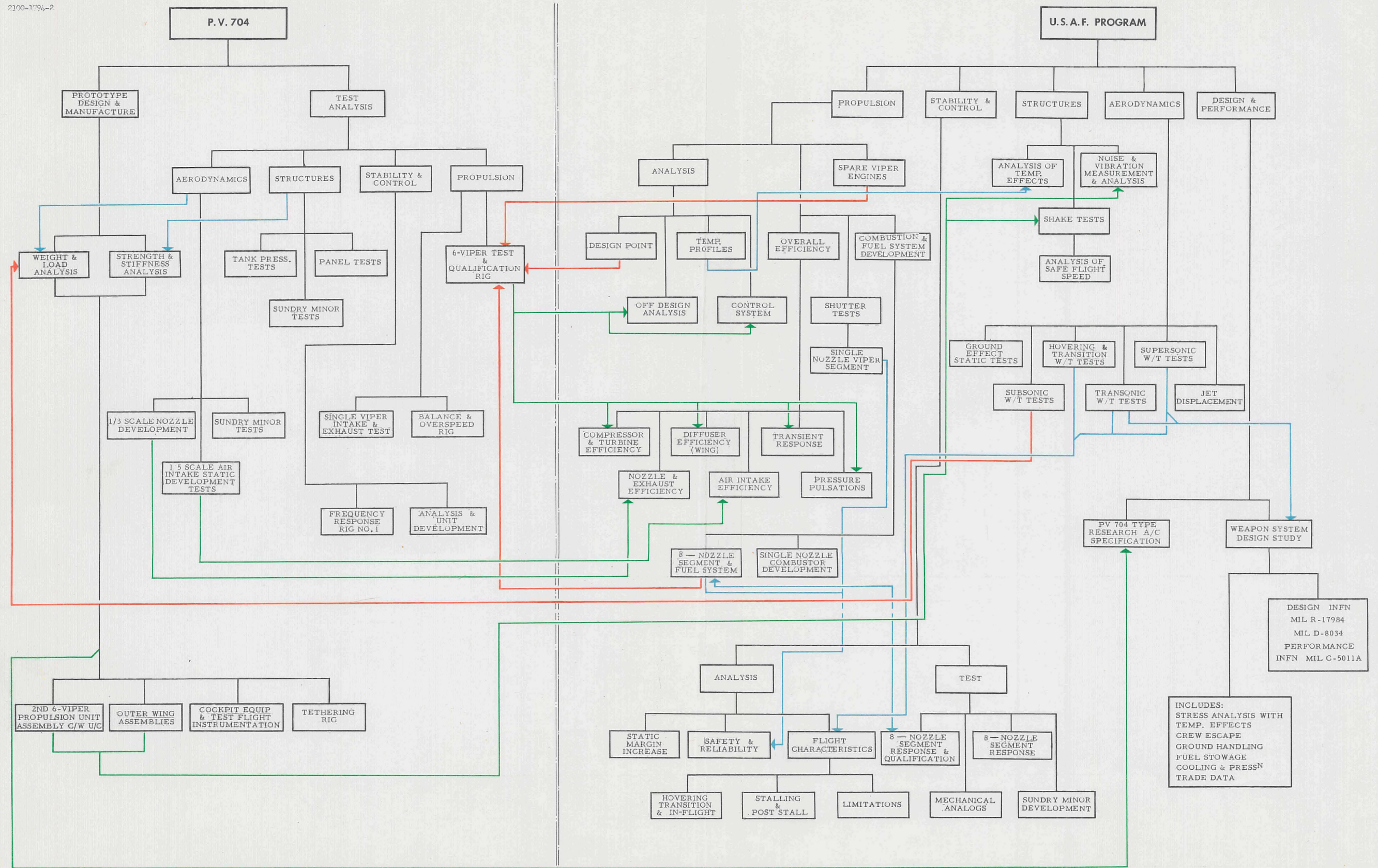

FIG.65 CONSOLIDATED WORK CHART

MANHOUR AND COST ESTIMATES

PROJECT 1794 EXTENSION PROGRAM (SUPPLEMENTAL AGREEMENT NO. 3)
 ANALYSIS OF ESTIMATED COSTS BY STATEMENT OF WORK THREE DIGIT SUB PART.

Statement of Work Sub Part 1.1.1 - Supersonic Tests

| <u>Engineering</u> | <u>Fiscal Year</u> | <u>Hours</u> | <u>Direct Labour Rate</u> | <u>Direct Labour Cost</u> | <u>Plant O/Head Rate</u> | <u>Plant O/Head Cost</u> | <u>Material & Direct Charges</u> | <u>Sub Total</u> | <u>Admin. O/Head Rate</u> | <u>Admin. O/Head Cost</u> | <u>Totals</u> | <u>Grand Totals</u> |
|----------------------------------|--------------------|------------------------------|---------------------------|---------------------------|--------------------------|--------------------------|--------------------------------------|------------------|---------------------------|---------------------------|---------------|---------------------|
| Design | 1956/7 | ^{1 Mon Yr} 2000 | \$ 2.75 | \$ 5,500 | 115% | \$ 6,325 | | \$ 11,825 | 7.5% | \$ 886 | \$ 12,711 | |
| Test Data Reduction and Reports | 1956/7/8/9 | ^{3 Mon Yrs} 6000 | 2.85 | 17,100 | 120% | 20,520 | | 37,620 | 9.0% | 3,385 | 41,005 | |
| Totals | | 8000 | | 22,600 | | 26,845 | | 49,445 | | 4,271 | | \$ 53,716 |
| <i>ess complete</i> | | | | | | | | | | | | |
| <u>Manufacturing</u> | | | | | | | | | | | | |
| Process Planning and Tool Design | 1956/7 | 500 | 2.75 | 1,375 | 115% | 1,581 | | 2,956 | 7.5% | 221 | 3,177 | |
| Manufacturing | 1956/7/8 | 3000 | 2.15 | 6,450 | 150% | 9,675 | \$ 2,000 | 18,125 | 9.0% | 1,631 | 19,756 | |
| Totals | | 3500 | | 7,825 | | 11,256 | 2,000 | 21,081 | | 1,852 | | 22,933 |
| | | | | | | | | | | | | 76,649 |

1,800
 18
 200

Statement of Work Sub Part 1.1.2 - Transonic Tests

| <u>Engineering</u> | <u>Fiscal Year</u> | <u>Hours</u> | <u>Direct Labour Rate</u> | <u>Direct Labour Cost</u> | <u>Plant O/Head Rate</u> | <u>Plant O/Head Cost</u> | <u>Material & Direct Charges</u> | <u>Sub Total</u> | <u>Admin. O/Head Rate</u> | <u>Admin. O/Head Cost</u> | <u>Totals</u> | <u>Grand Totals</u> |
|----------------------------------|--------------------|--------------|---------------------------|---------------------------|--------------------------|--------------------------|--------------------------------------|------------------|---------------------------|---------------------------|---------------|---------------------|
| Design | 1956/7 | 6500 | 2.75 | \$ 17,875 | 115% | \$ 20,556 | | \$ 38,431 | 7.5% | \$ 2,882 | \$ 41,313 | |
| Test Data Reduction and Reports | 1957/8/9 | 6000 | 2.85 | 17,100 | 120% | 20,520 | | 37,620 | 9.0% | 3,385 | 41,005 | |
| Totals | | 12500 | | 34,975 | | 41,076 | | 76,051 | | 6,267 | 82,318 | \$ 82,318 |
| <u>Manufacturing</u> | | | | | | | | | | | | |
| Process Planning and Tool Design | 1956/7 | 1000 | 2.75 | 2,750 | 115% | 3,162 | | 5,912 | 7.5% | 443 | 6,355 | |
| Manufacturing | 1956/7/8 | 10000 | 2.15 | 21,500 | 150% | 32,250 | \$ 6,986 | 60,736 | 9.0% | 5,466 | 66,202 | |
| Totals | | 11000 | | 24,250 | | 35,412 | 6,986 | 66,648 | | 5,909 | 72,557 | 72,557 |
| | | | | | | | | | | | 154,875 | |

Statement of Work Sub Part 1.1.3 - Subsonic Tests

| <u>Engineering</u> | <u>Fiscal Year</u> | <u>Hours</u> | <u>Direct Labour Rate</u> | <u>Direct Labour Cost</u> | <u>Plant O/Head Rate</u> | <u>Plant O/Head Cost</u> | <u>Material & Direct Charges</u> | <u>Sub Total</u> | <u>Admin. O/Head Rate</u> | <u>Admin. O/Head Cost</u> | <u>Totals</u> | <u>Grand Totals</u> |
|----------------------------------|--------------------|--------------|---------------------------|---------------------------|--------------------------|--------------------------|--------------------------------------|------------------|---------------------------|---------------------------|---------------|---------------------|
| Design | 1956/7 | 2000 | \$ 2.75 | \$ 5,500 | 115% | \$ 6,325 | | \$ 11,825 | 7.5% | \$ 886 | \$ 12,711 | |
| Test Data Reduction and Reports | 1957/8/9 | 5000 | 2.85 | 14,250 | 120% | 17,100 | | 31,350 | 9.0% | 2,821 | 34,171 | |
| Totals | | 7000 | | 19,750 | | 23,425 | | 43,175 | | 3,707 | 46,882 | \$ 46,882 |
| <u>Manufacturing</u> | | | | | | | | | | | | |
| Process Planning and Tool Design | 1956/7 | 500 | 2.75 | 1,375 | 115% | 1,581 | | 2,956 | 7.5% | 221 | 3,177 | |
| Manufacturing | 1957/8 | 5000 | 2.15 | 10,750 | 150% | 16,125 | \$ 5,000 | 31,875 | 9.0% | 2,868 | 34,743 | |
| Totals | | 5500 | | 12,125 | | 17,706 | 5,000 | 34,831 | | 3,089 | 37,920 | 37,920 |
| | | | | | | | | | | | 84,802 | |

1/6 scale - completely designed - nowking mfg 26aug

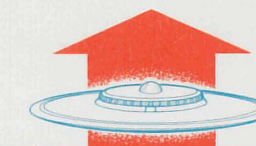

*\$ 69,000 for
goose made -
100,000 for -
+ 4% being
discussed
now.*

Statement of Work Sub Part 1.1.4 - Hover and Transition Tests

| <u>Engineering</u> | <u>Fiscal Year</u> | <u>Hours</u> | <u>Direct Labour Rate</u> | <u>Direct Labour Cost</u> | <u>Plant O/Head Rate</u> | <u>Plant O/Head Cost</u> | <u>Material & Direct Charges</u> | <u>Sub Total</u> | <u>Admin. O/Head Rate</u> | <u>Admin. O/Head Cost</u> | <u>Totals</u> | <u>Grand Totals</u> |
|----------------------------------|--------------------|--------------|---------------------------|---------------------------|--------------------------|--------------------------|--------------------------------------|------------------|---------------------------|---------------------------|---------------|---------------------|
| Design | 1956/7 | 3000 | \$ 2.75 | \$ 8,250 | 115% | \$ 9,487 | | \$ 17,737 | 7.5% | \$ 1,330 | \$ 19,067 | |
| Test Data Reduction and Reports | 1957/8/9 | 6000 | 2.85 | 17,100 | 120% | 20,520 | | 37,620 | 9.0% | 3,385 | 41,005 | |
| Totals | | 9000 | | 25,350 | | 30,007 | | 55,357 | | 4,715 | 60,072 | \$ 60,072 |
| <u>Manufacturing</u> | | | | | | | | | | | | |
| Process Planning and Tool Design | 1956/7 | 500 | 2.75 | 1,375 | 115% | 1,581 | | 2,956 | 7.5% | 221 | 3,177 | |
| Manufacturing | 1956/7/8 | 7500 | 2.15 | 16,125 | 150% | 24,187 | 3,000 | 43,312 | 9.0% | 3,898 | 47,210 | |
| Totals | | 8000 | | 17,500 | | 25,768 | 3,000 | 46,268 | | 4,119 | 50,387 | 110,459 |
| | | | | | | | | | | | | 170,531 |

*all engs
Partly costs.*

*Fortunately, grand
Totals not used in
Summary, Page 101,
So error does
not carry into
total cost
R.*

Statement of Work Sub Part 1.1.5 - Air and Exhaust Gas Flow

| <u>Engineering</u> | <u>Fiscal Year</u> | <u>Hours</u> | <u>Direct Labour Rate</u> | <u>Direct Labour Cost</u> | <u>Plant O/Head Rate</u> | <u>Plant O/Head Cost</u> | <u>Material & Direct Charges</u> | <u>Sub Total</u> | <u>Admin. O/Head Rate</u> | <u>Admin. O/Head Cost</u> | <u>Totals</u> | <u>Grand Totals</u> |
|---------------------------------|--------------------|----------------------|---------------------------|---------------------------|--------------------------|--------------------------|--------------------------------------|------------------|---------------------------|---------------------------|---------------|---------------------|
| Test Data Reduction and Reports | 1957/8/9 | 22600 <i>11.3</i> | \$ 2.85 | \$ 64,410 | 120% | \$ 77,292 | | \$ 141,702 | 9.0% | \$ 12,753 | \$ 154,455 | \$ 154,455 |

4 mos effort - cont. to end, work from 6 Viper test rig -

Statement of Work Sub Part 1.1.6 - Propulsion System

| <u>Engineering</u> | <u>Fiscal Year</u> | <u>Hours</u> | <u>Direct Labour Rate</u> | <u>Direct Labour Cost</u> | <u>Plant O/Head Rate</u> | <u>Plant O/Head Cost</u> | <u>Material & Direct Charges</u> | <u>Sub Total</u> | <u>Admin. O/Head Rate</u> | <u>Admin. O/Head Cost</u> | <u>Totals</u> | <u>Grand Totals</u> |
|---------------------------------|--------------------|----------------------|---------------------------|---------------------------|--------------------------|--------------------------|--------------------------------------|------------------|---------------------------|---------------------------|---------------|---------------------------------------|
| Test Data Reduction and Reports | 1956/7/8/9 | 6000 <i>3 mos</i> | 2.85 | 17,100 | 120% | 20,520 | | 37,620 | 9.0% | 3,385 | 41,005 | 41,005 <i>1640</i> <i>42640</i> |

about 40% done

Statement of Work Sub Part 1.1.7 - Propulsion System Component Tests

| <u>Engineering</u> | <u>Fiscal Year</u> | <u>Material & Direct Charges</u> | <u>Totals</u> |
|---|--------------------|--------------------------------------|---------------|
| Combustion Fuel System Design Development Tests and Reports | 1956/7/8/9 | \$ 430,960 Sub Contract | 430,960 |

*Test rigs built
not fully installed -
some eng work done - committed for material
can't est how much expended.
last 8 cans del by end of nov.*

*9%
Admin
\$ 469,747*

*↑
EPA Inadvertently omitted*

Statement of Work Sub Part 1.1.8 - Stability and Control

| <u>Engineering</u> | <u>Fiscal Year</u> | <u>Hours</u> | <u>Direct Labour Rate</u> | <u>Direct Labour Cost</u> | <u>Plant O/Head Rate</u> | <u>Plant O/Head Cost</u> | <u>Material & Direct Charges</u> | <u>Sub Total</u> | <u>Admin. O/Head Rate</u> | <u>Admin. O/Head Cost</u> | <u>Totals</u> | <u>Grand Totals</u> |
|--|--------------------|--------------|---------------------------|---------------------------|--------------------------|--------------------------|--------------------------------------|------------------|---------------------------|---------------------------|---------------|---------------------|
| Test Data Reduction and Reports | 1956/7/8/9 | 14000 | \$ 2.85 | \$ 39,900 | 120% | \$ 47,880 | | \$ 87,780 | 9.0% | \$ 7,900 | \$ 95,680 | |
| | | | | | | | | | | | | |
| <i>continuous study during course of contract.</i> | | | | | | | | | | | | |
| <u>Manufacturing</u> | | | | | | | | | | | | |
| Manufacturing | 1956/7/8 | 1000 | 2.15 | 2,150 | 150% | 3,225 | \$ 1,360 | 6,735 | 9.0% | 606 | 7,341 | |
| Totals | | 15000 | | 42,050 | | 51,105 | 1,360 | 94,515 | | 8,506 | 103,021 | \$ 103,021 |

Statement of Work Sub Part 1.1.9 - Weapons System Study

| <u>Engineering</u> | <u>Fiscal Year</u> | <u>Hours</u> | <u>Direct Labour Rate</u> | <u>Direct Labour Cost</u> | <u>Plant O/Head Rate</u> | <u>Plant O/Head Cost</u> | <u>Material & Direct Charges</u> | <u>Sub Total</u> | <u>Admin. O/Head Rate</u> | <u>Admin. O/Head Cost</u> | <u>Totals</u> | <u>Grand Totals</u> |
|-----------------------|--------------------|--------------|---------------------------|---------------------------|--------------------------|--------------------------|--------------------------------------|------------------|---------------------------|---------------------------|---------------|---------------------|
| Weapons Systems Study | 1956/7/8/9 | 21600 | \$ 2.85 | \$ 61,560 | 120% | \$ 73,872 | | \$ 135,432 | 9.0% | \$ 12,189 | \$ 147,621 | \$ 147,621 |

PROJECT 1794 EXTENSION

SUMMARY OF COSTS

| | <u>Fiscal Year</u> | <u>Hours</u> | <u>Direct Labour Rate</u> | <u>Direct Labour Cost</u> | <u>Plant O/Head Rate</u> | <u>Plant O/Head Cost</u> | <u>Material & Direct Charges</u> | <u>Sub Total</u> | <u>Admin. O/Head Rate</u> | <u>Admin. O/Head Cost</u> | <u>Totals</u> | <u>Grand Totals</u> |
|--|--------------------|------------------------------|---------------------------|---------------------------|--------------------------|--------------------------|--------------------------------------|------------------|---------------------------|---------------------------|---------------|---------------------|
| <u>Engineering</u> | | | | | | | | | | | | |
| Design | 1956/7 | 13500 ^{6.75 hrs/yr} | \$ 2.75 | \$ 37,125 | 115% | \$ 42,693 | | \$ 79,818 | 7.5% | \$ 5,984 | \$ 85,802 | |
| Test Data Reduction and Reports, Weapons Systems Study | 1956/7/8/9 | 87200 ^{43.6} | 2.85 | 248,520 | 120% | 298,224 | | 546,744 | 9.0% | 49,203 | 595,947 | |
| Totals | | 100700 | | 285,645 | | 340,917 | | 626,562 | | 55,187 | | \$ 681,749 |
| <u>Manufacturing</u> | | | | | | | | | | | | |
| Process Planning and Tool Design | 1956/7 | 2500 | 2.75 | 6,875 | 115% | 7,905 | | 14,780 | 7.5% | 1,106 | 15,886 | |
| Manufacturing | 1956/7/8 | 26500 | 2.15 | 56,975 | 150% | 85,462 | \$ 18,346 | 160,783 | 9.0% | 14,469 | 175,252 | |
| Totals | | 29000 | | 63,850 | | 93,367 | 18,346 | 175,563 | | 15,575 | | 191,138 |
| Combustion and Fuel Systems Design and Development - Sub Contract - Lucas Rotex Limited per estimate. 6 A.S.M. Viper 8 Standard Provost Type Engines | | | | | | | | 430,960 | 9.0% | 38,787 | 469,747 | |
| | | | | | | | | | 7.5% | 13,500 | 193,500 | |
| GRAND TOTAL..... | | | | | | | | | | | \$ 1,536,134 | |

ALL AMOUNTS SHOWN IN CANADIAN FUNDS

Cost for Wind Tunnel Facilities not included

Handwritten calculations:
 52,000
 614,453.6
 1,517,579
 48,000
 1,641,579
 16
 48,579

2375-704-1

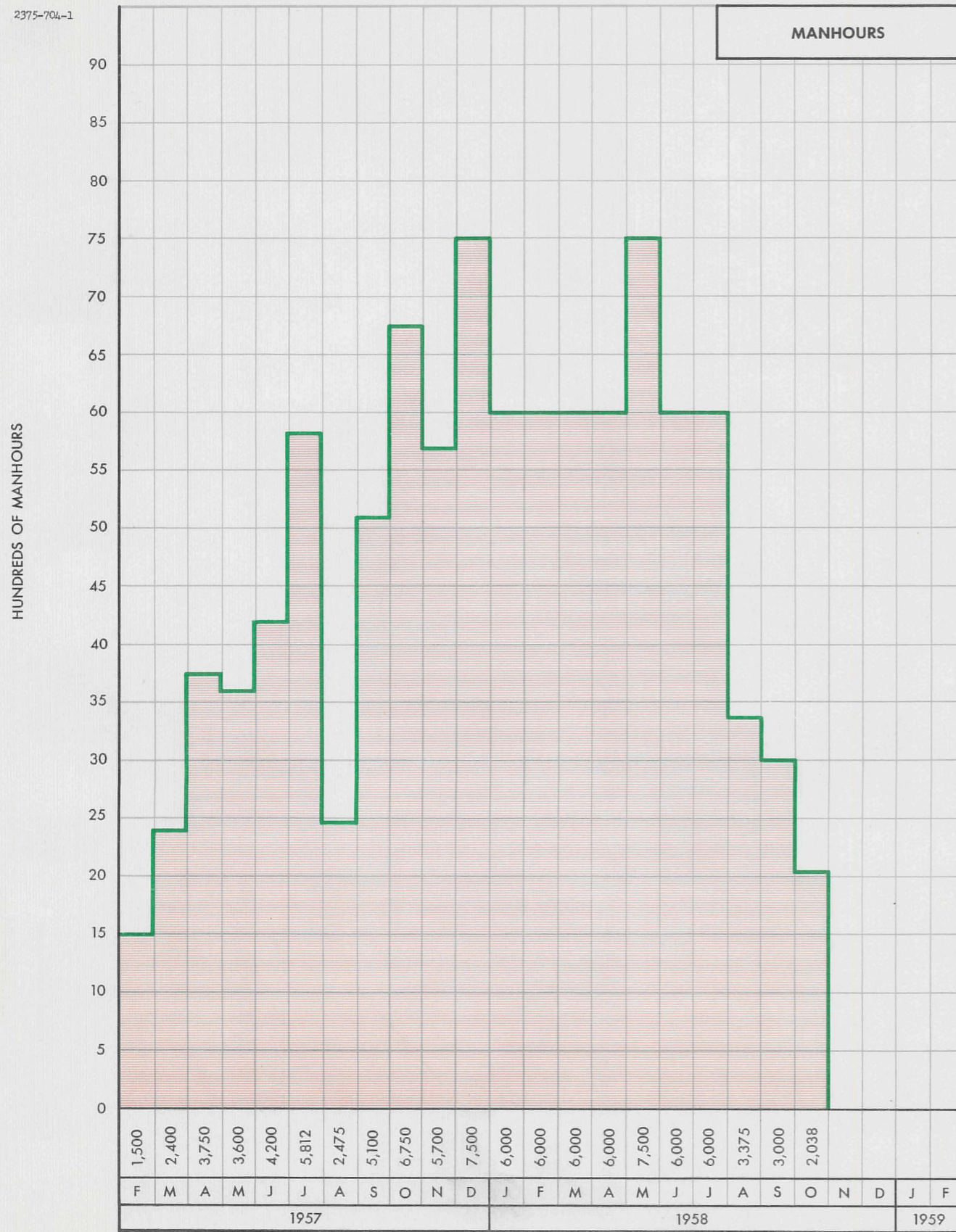

THOUSANDS OF DOLLARS

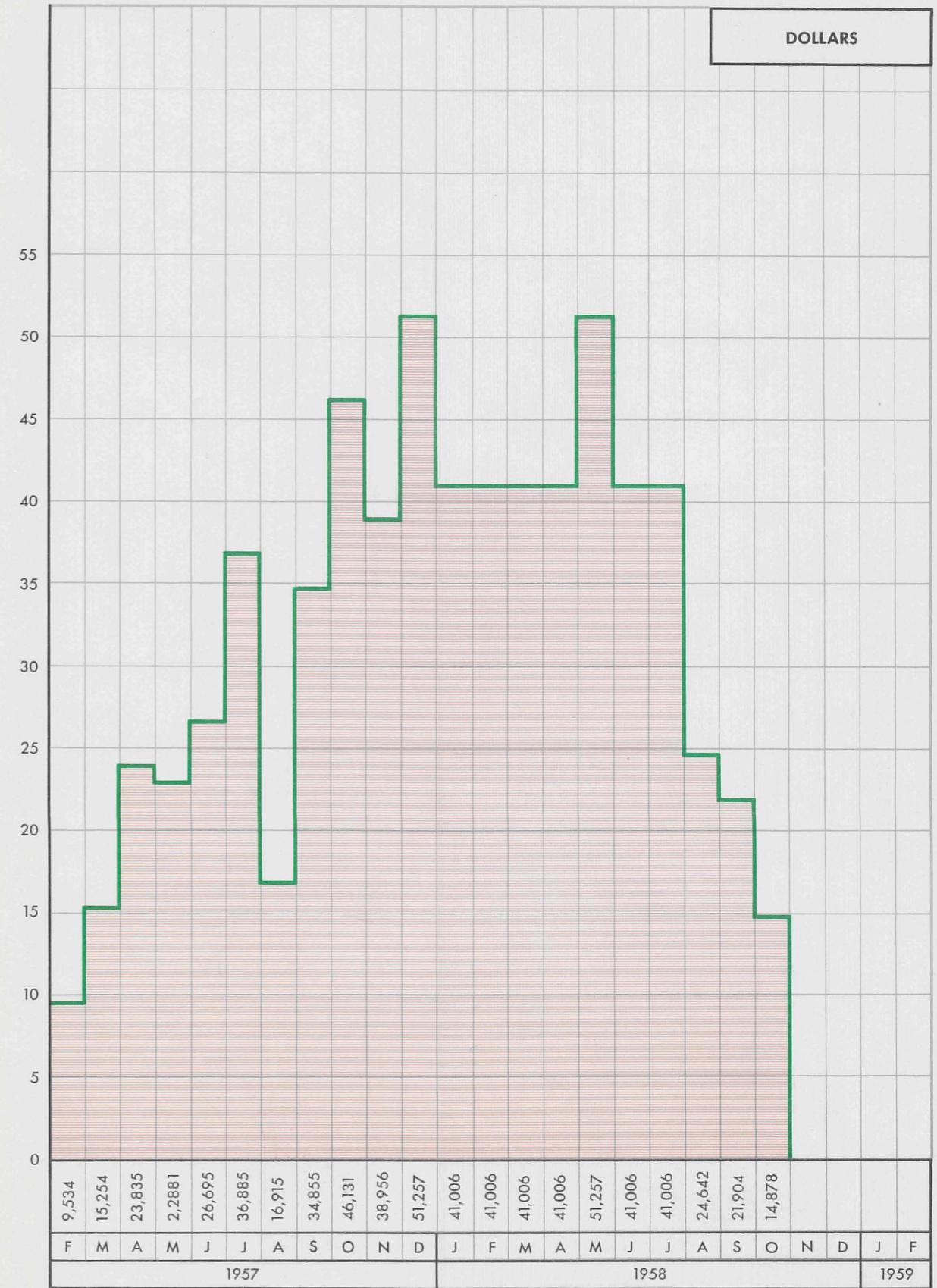

MONTHLY BREAKDOWN - ENGINEERING MANHOURS AND DOLLARS

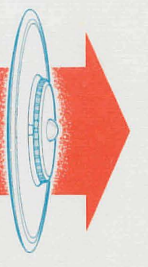

THOUSANDS OF MANHOURS



THOUSANDS OF DOLLARS

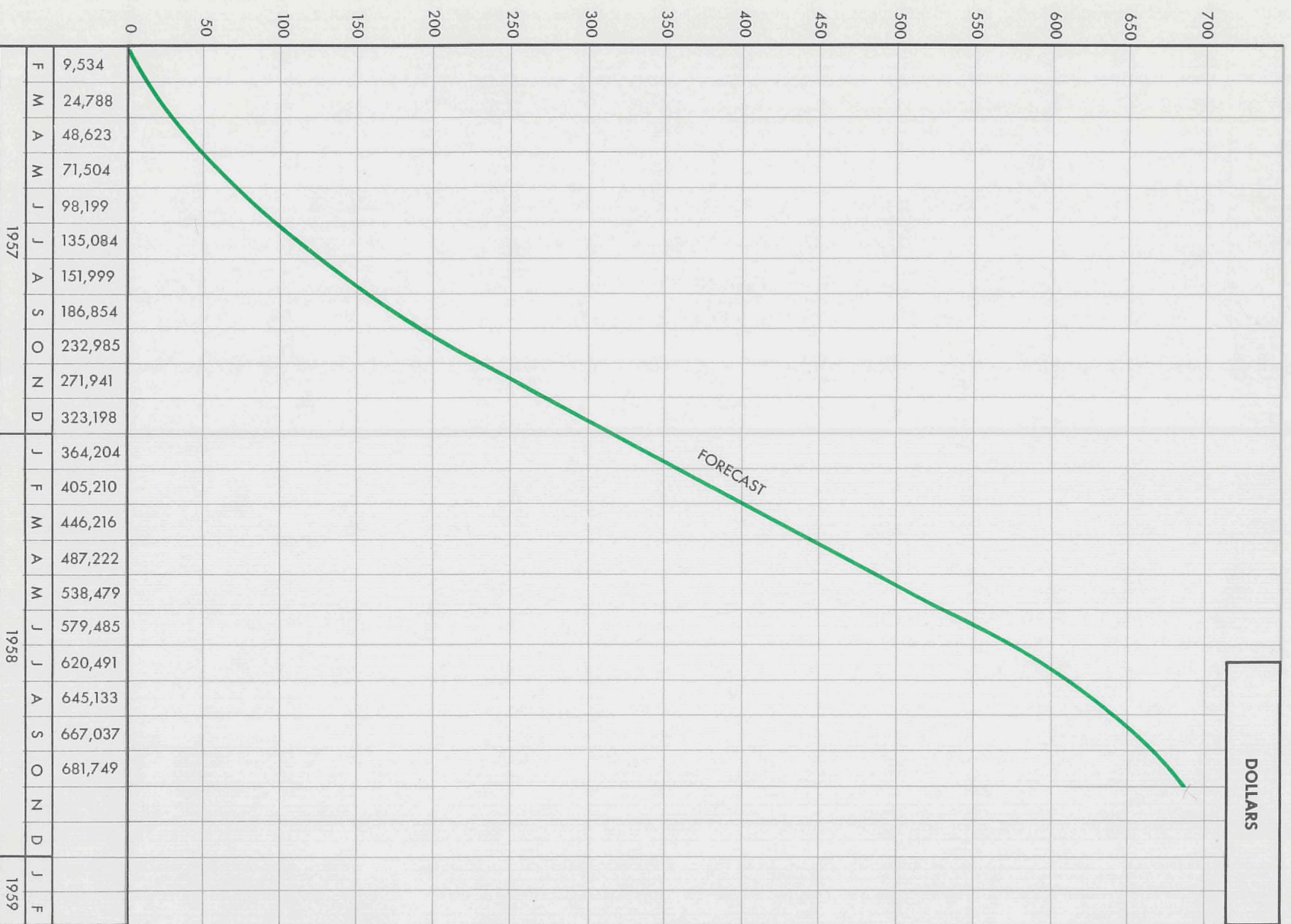

ENGINEERING MANHOURS AND DOLLARS - CUMULATIVE

SECRET

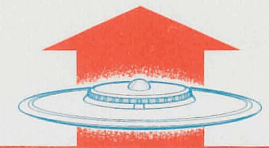

23771-704-1

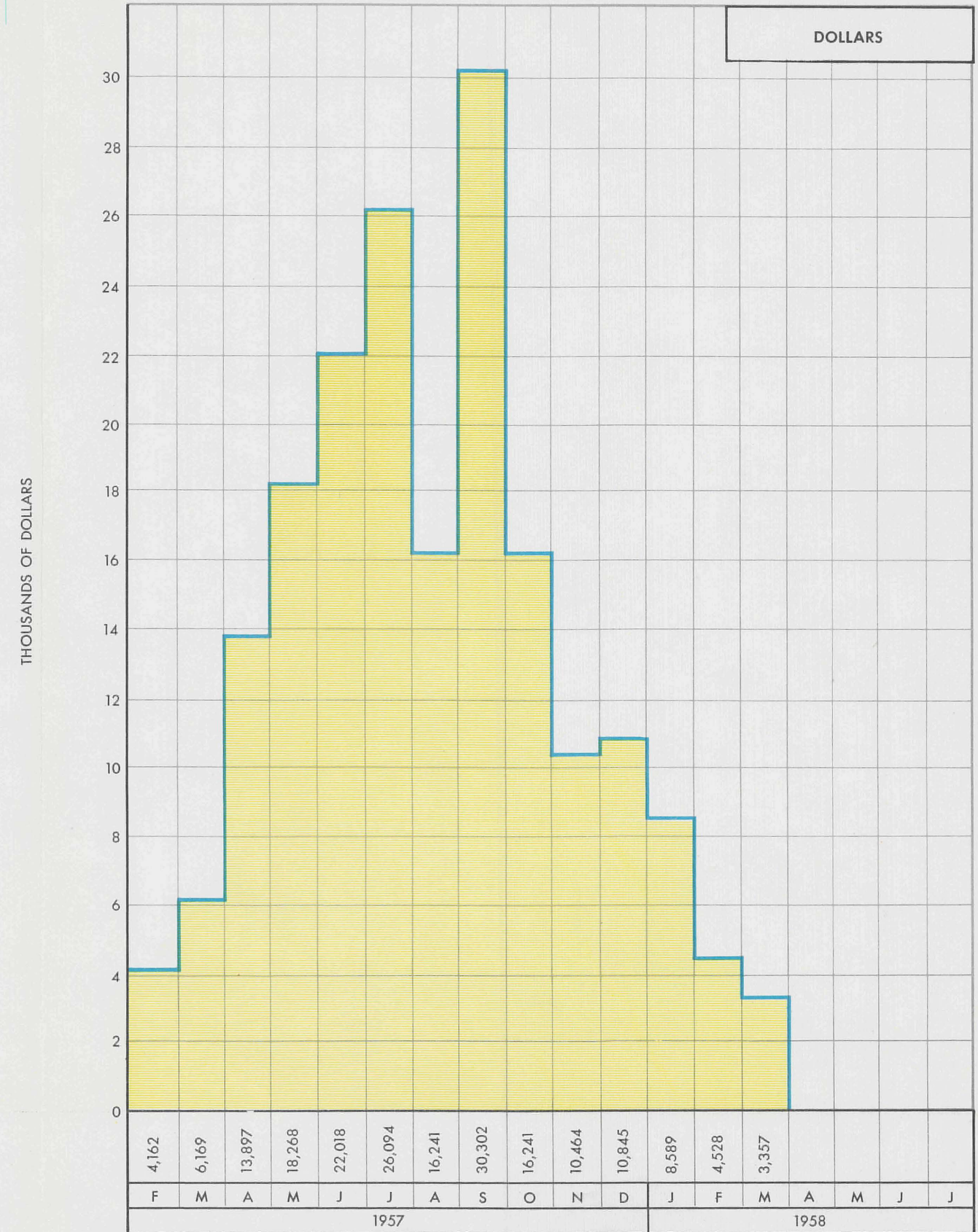
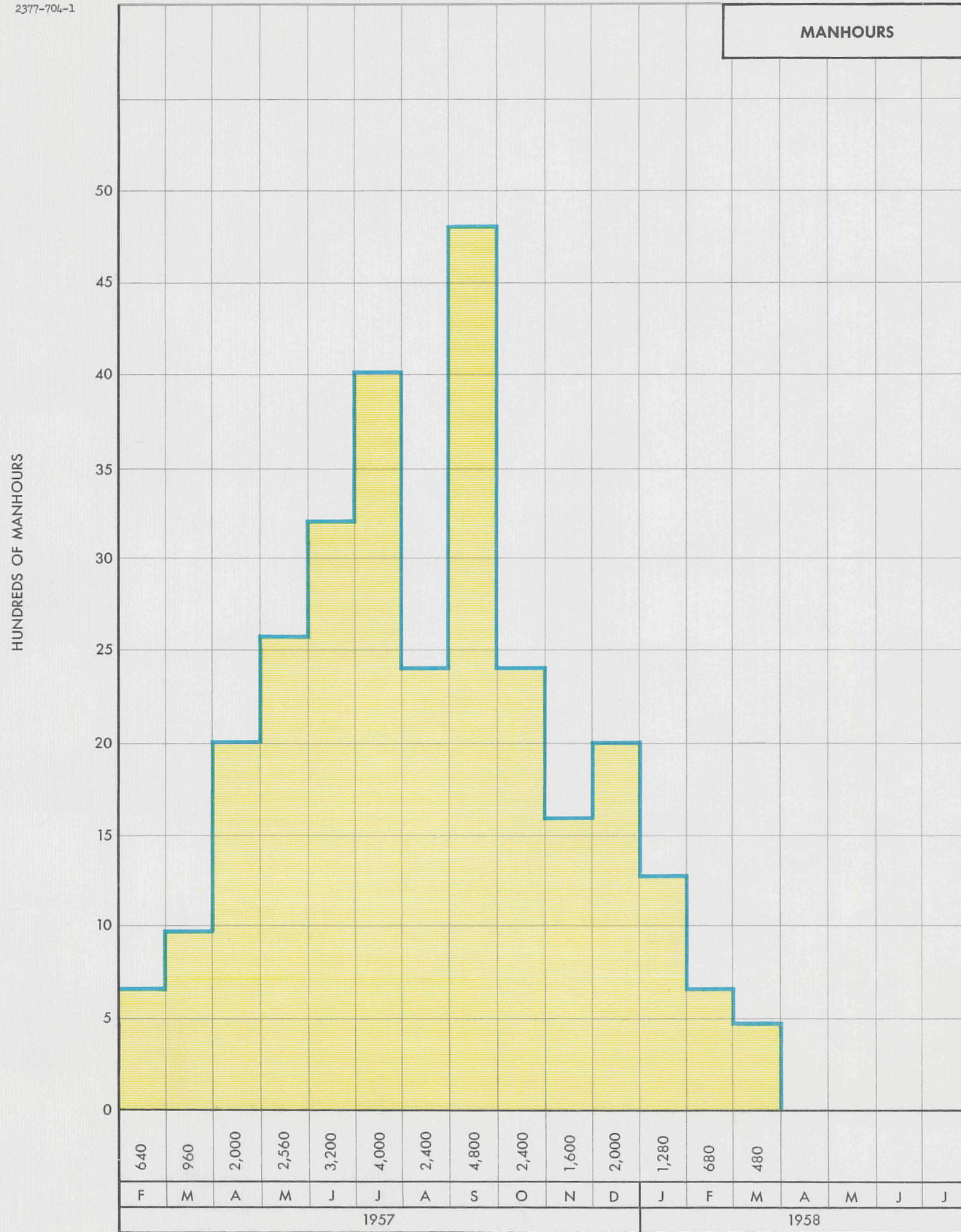

MONTHLY BREAKDOWN MANUFACTURING MANHOURS AND DOLLARS

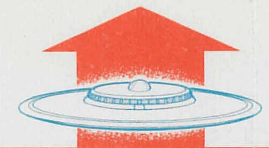

2376-704-1

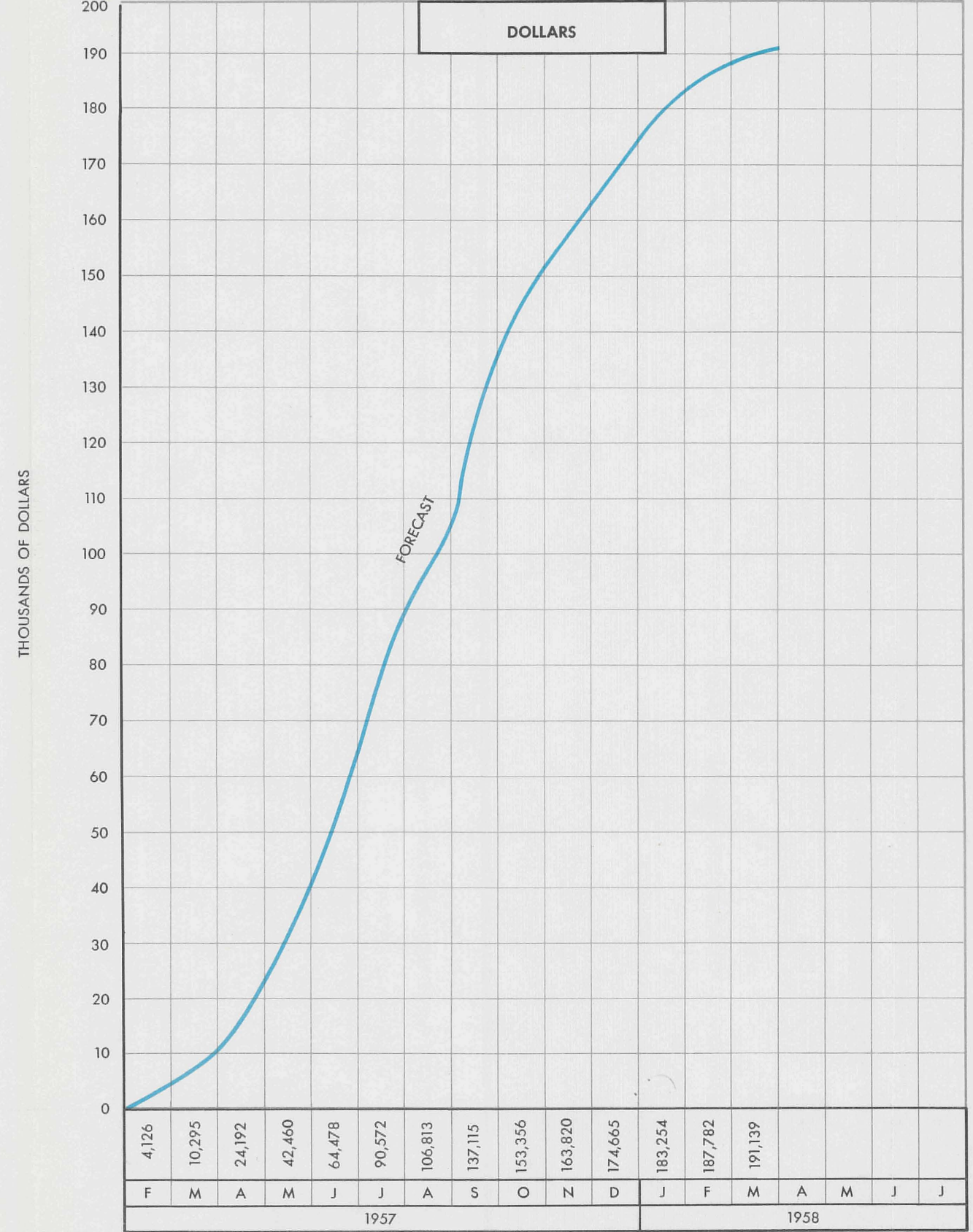
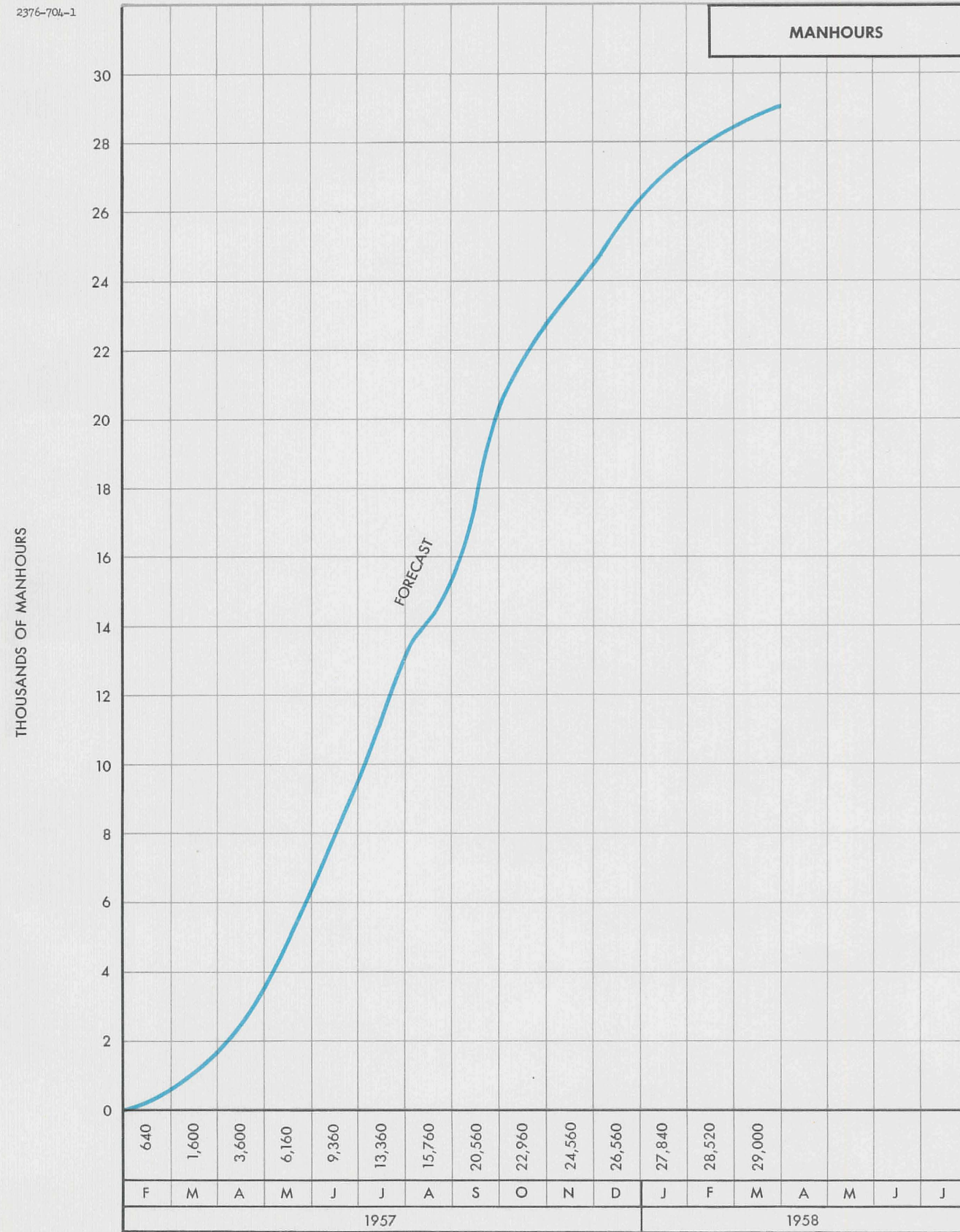

MANUFACTURING MANHOURS AND DOLLARS - CUMULATIVE

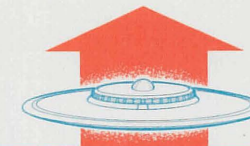

2378-704-1

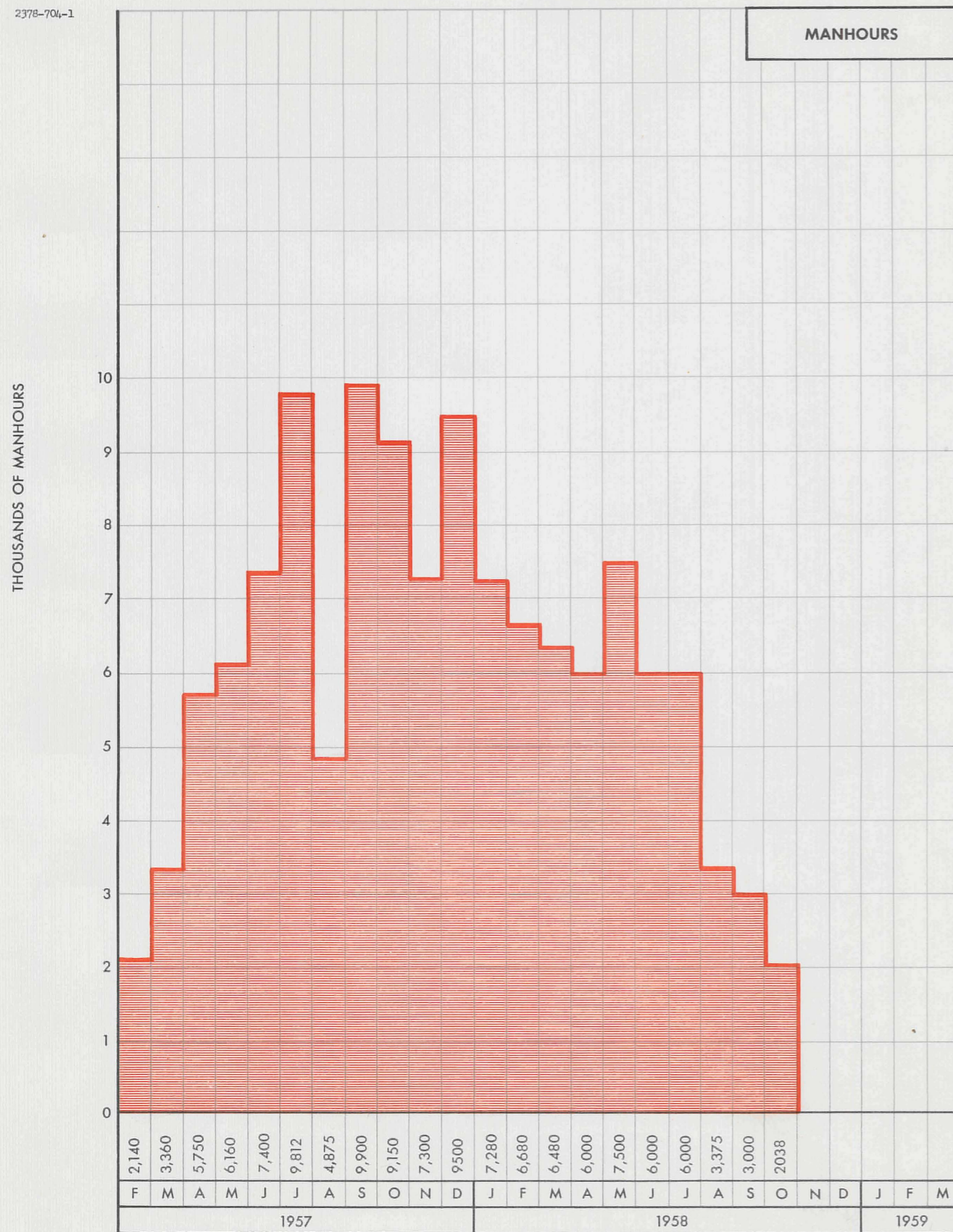

MONTHLY BREAKDOWN TOTAL ENGINEERING AND MANUFACTURING MANHOURS AND DOLLARS

THOUSANDS OF MANHOURS



THOUSANDS OF DOLLARS



TOTAL ENGINEERING AND MANUFACTURING MANHOURS AND DOLLARS - CUMULATIVE

SECRET

PROJECT 1794

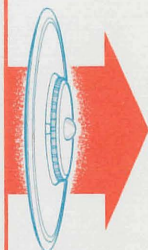

2380-704-1

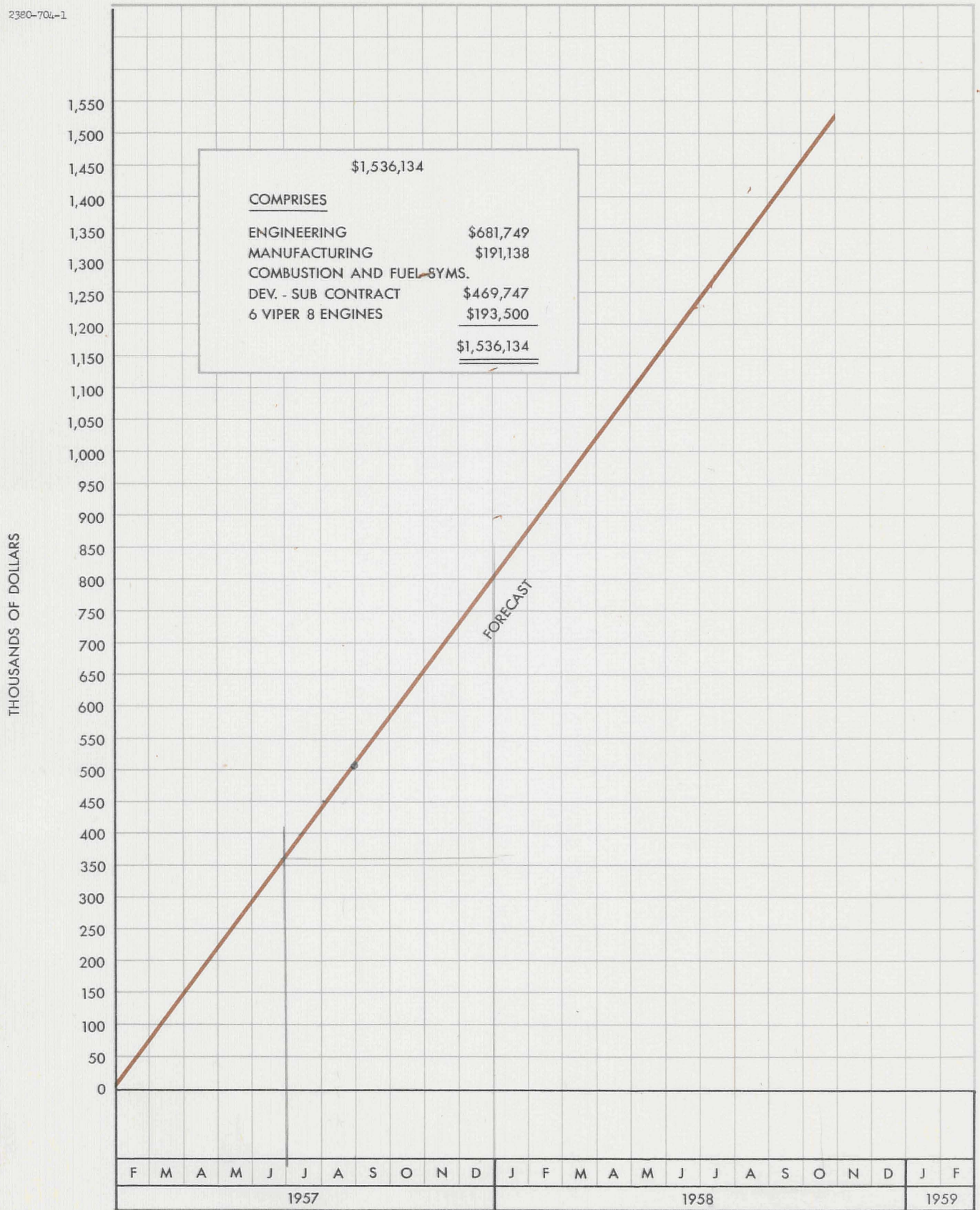

PROGRAM TOTAL DOLLAR COST

SPECIAL PROJECTS GROUP PERSONNEL

| | <u>No. of Personnel</u> |
|--------------------------------|-----------------------------|
| Chief Design Engineer | 1 |
| Project Designer | 1 |
| Senior Design Engineer | 1 |
| Senior Designer | 5 |
| Designer A/C | 6 |
| Design Draftsman | 6 |
| Draftsman 'A' | 8 |
| Draftsman 'B' | 2 |
| Senior Loftsmen | 1 |
| Lines Loftsmen 'B' | 6 |
| Chief Aerodynamicist | 1 |
| Sr. Aerodynamicist | 1 |
| Aerodynamicist - Engineering | 4 |
| Thermodynamicist | 1 |
| Aerodynamicist 'A' | 8 |
| Senior Stress Engineer | 1 |
| Stress Engineer 'A' | 2 |
| Stress Engineer 'B' | 4 |
| Junior Stress Engineer | 3 |
| Junior Aerodynamicist Engineer | 3 |
| Weights Estimator 'A' | 1 |



The following rates of Labour and Overhead have been applied in the compilation of costs estimates for the program of work outlined in this proposal.

Labour Rates

| | | |
|------------------|------------------------|---------|
| For Engineering | Year Ending July 31/57 | \$ 2.75 |
| | Year Ending July 31/58 | 2.85 |
| | Year Ending July 31/59 | 2.95 |
| For Experimental | Year Ending July 31/57 | 2.10 |
| | Year Ending July 31/58 | 2.15 |
| | Year Ending July 31/59 | 2.20 |

Overhead Rates

| | | |
|--------------------|------------------------|-------|
| For Engineering | Year Ending July 31/57 | 115% |
| | Year Ending July 31/58 | 120% |
| | Year Ending July 31/59 | 125% |
| For Experimental | Year Ending July 31/57 | 150% |
| | Year Ending July 31/58 | 150% |
| | Year Ending July 31/59 | 150% |
| For Administrative | Year Ending July 31/57 | 7.5% |
| | Year Ending July 31/58 | 9.0% |
| | Year Ending July 31/59 | 10.0% |

Application of Rates

Labour + Overhead + Material and Direct Charges + Administrative.

9. COMPANY STATEMENTSManagement

The program of work specified in this proposal will be managed in all phases of Engineering, Administration and Experiment Manufacturing by the same management personnel who were responsible for the previous Project 1794 program and whose responsibilities are shown in Exhibit 1 and Exhibit 2.

Should it be found necessary during the contract period to effect changes (in the interest of the work) of key personnel or their responsibilities, this will only be done after consultation with the United States Air Force.

Facilities

The contractors will provide all the facilities necessary, to accomplish the program of work specified in this proposal, with the exception of Wind Tunnel facilities which are to be furnished by the United States Government.

Personnel

The contractor undertakes to provide professional, skilled, semi-skilled and other classifications of labour in sufficient numbers to support the program.



BOARD OF DIRECTORS
 CRAWFORD GORDON, Jr. - CHAIRMAN
 F.T. SMYE - PRESIDENT AND GENERAL MANAGER
 A.A. BAILIE - DIRECTOR
 J.C. FLOYD - VICE-PRESIDENT ENGINEERING
 J.A. MORLEY - VICE-PRESIDENT SALES AND SERVICE
 H.R. SMITH - VICE-PRESIDENT MANUFACTURING
 J. TURNER - VICE-PRESIDENT FINANCE

OFFICERS
 F.H. WILLIAMS - TREASURER
 N.E. KINDELL - SECRETARY

PRESIDENT AND GENERAL MANAGER
 F.T. SMYE

ASSISTANT TO THE PRESIDENT
 W.V. HURLEY

PUBLIC RELATIONS MANAGER
 A.H. STEWART

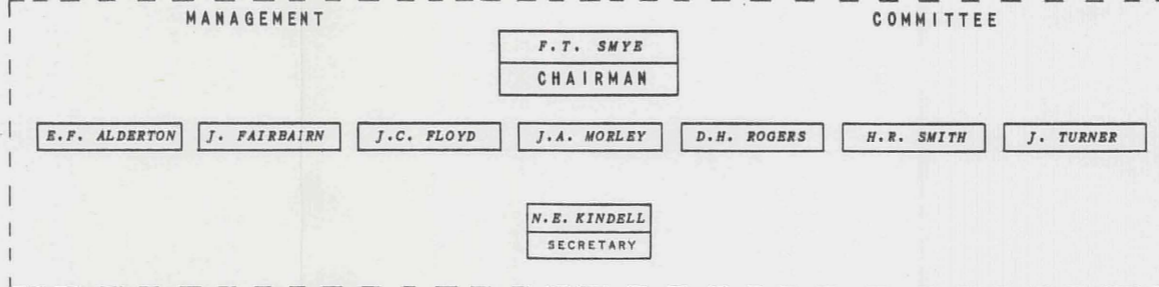

ENGINEERING DIVISION

VICE-PRESIDENT ENGINEERING
 J.C. FLOYD

EXECUTIVE ASSISTANT
 L.C. McCARTY

- CHIEF DESIGN ENGINEER
R.N. LINDLEY
- CHIEF ADMINISTRATIVE ENGINEER
R. ADEY
- CHIEF EXPERIMENTAL ENGINEER
S.E. HARPER
- EXPERIMENTAL MANAGER
J.W. KENNY
- CHIEF TECHNICIAN
J. CHAMBERLIN
- CHIEF AERODYNAMICIST
- PROJECT DESIGNER CF-105
G. HAKE
- PROJECT DESIGNER CF-100
C.V. LINDOW
- ASSISTANT CHIEF DESIGN ENGINEER (ARMAMENT)
G.R. OSCAR

FINANCE DIVISION

VICE-PRESIDENT FINANCE
 J. TURNER

- COMPTROLLER & TREASURER
F.H. WILLIAMS
- SECRETARY
N.E. KINDELL

FLIGHT OPERATIONS DIVISION

CHIEF OF FLIGHT OPERATIONS
 D.H. ROGERS

INDUSTRIAL RELATIONS DIVISION

INDUSTRIAL RELATIONS MANAGER
 E.F. ALDERTON

MANUFACTURING DIVISION

VICE-PRESIDENT MANUFACTURING
 H.R. SMITH

- INDUSTRIAL ENGINEERING MANAGER
S.L.H. WILSON
- PLANT ENGINEER
F.C. RICHARDSON
- PRODUCTION ENGINEERING MANAGER
H.F. YOUNG
- MATERIAL PROCUREMENT MANAGER
C.N. LUCAS
- PRODUCTION CONTROL MANAGER
N. PARSONS
- PRODUCTION SHOPS MANAGER
W.H. RIGGS
- ASSISTANT PRODUCTION ENGINEERING MANAGER
E.B. BRAGG
- PRODUCTION FLIGHT TEST GENERAL SUPERINTENDENT
D.R. WAGNER

QUALITY CONTROL & INSPECTION DIVISION

QUALITY CONTROL & INSPECTION MANAGER
 J. FAIRBAIRN

SALES & SERVICE DIVISION

VICE-PRESIDENT SALES & SERVICE
 J.A. MORLEY

SALES & SERVICE MANAGER
 M.D. WILLER

- SERVICE MANAGER
F.C. PLUMB
- PARTS MANAGER
D. MELDRUM
- MILITARY SALES MANAGER
R.M. HAWLEY
- CONTRACTS ADMINISTRATOR
J.R. DOUGLAS

SPECIAL PROJECTS GROUP

- CHIEF DESIGN ENGINEER
J.C.M. FROST
- ENGINEERING MANAGER
H.C. MOODY

APPROVED

F.T. Smye

PRESIDENT & GENERAL MANAGER



AVRO AIRCRAFT LIMITED

SPECIAL PROJECTS GROUP

SPECIAL PROJECTS GROUP

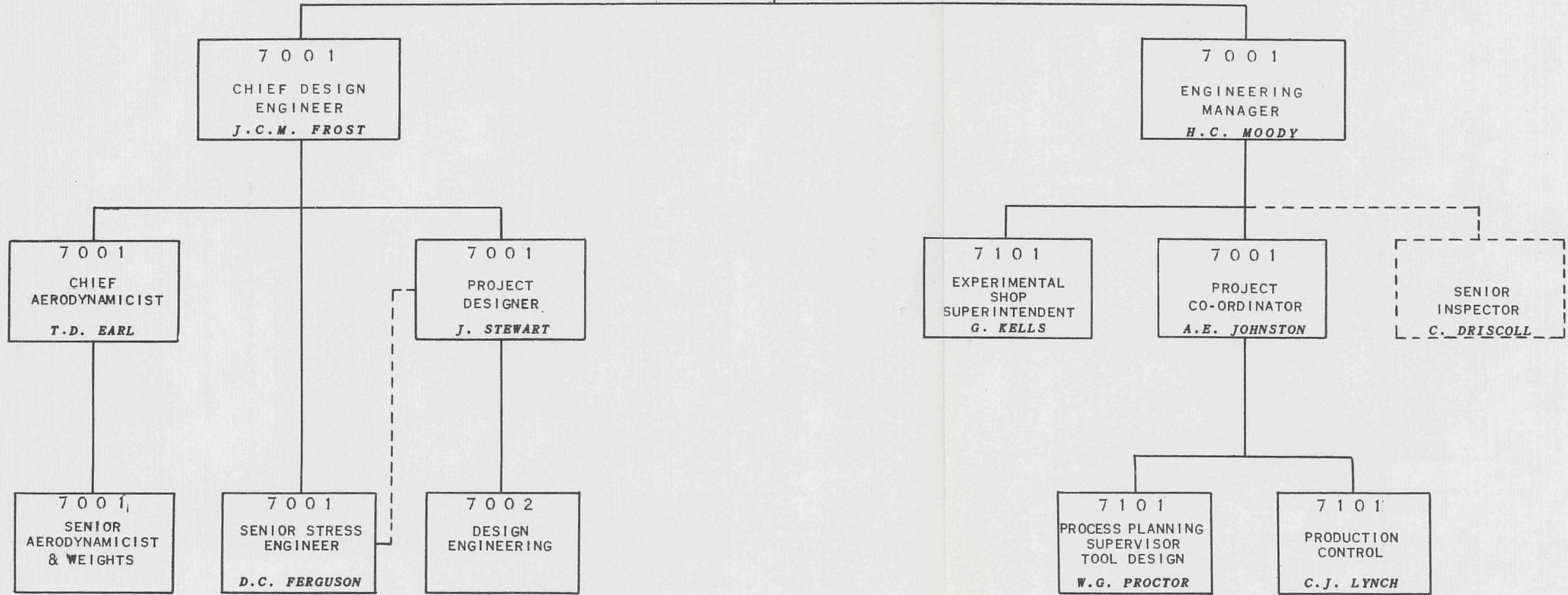

APPROVED

A.C. Moody
ENGINEERING MANAGER

APPROVED

J.J. Smye
PRESIDENT & GENERAL MANAGER